

Klein®

CNC ROUTER TOOLING
AND ACCESSORIES

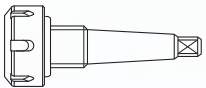

SOLID CARBIDE SPIRAL CUTTERS, TOOLHOLDERS AND ACCESSORIES FOR CNC ROUTER MACHINES



CONCENTRIC CHUCKS S-MK2
Page 6

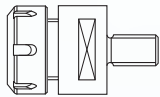

CONCENTRIC CHUCKS
Page 6

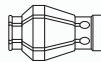

SPRING COLLETS
Page 6

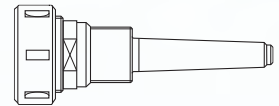

COLLET CHUCKS MORSE TAPER
Page 7

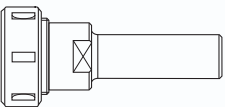

COLLET CHUCKS CYL SHANK \varnothing 20
Page 7

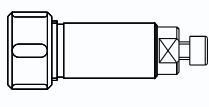

COLLET CHUCKS CYL SHANK \varnothing 25
Page 7

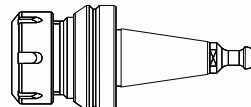

**COLLET CHUCKS ISO 30
TAPERED FLANGE**
Page 7

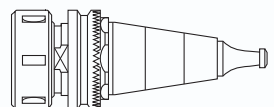

**COLLET CHUCKS ISO 30
SCM/MORBIDELLI**
Page 8

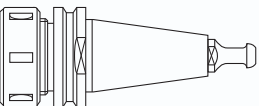

COLLET CHUCKS ISO 30
Page 8

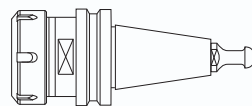

EXTENDED COLLET CHUCKS ISO 30
Page 9

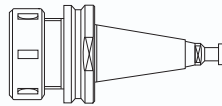

COLLET CHUCKS ISO 30 WITH FLANGE \varnothing 58
Page 9

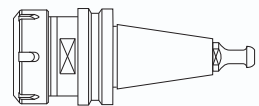

**COLLET CHUCKS ISO 30
WITH FLANGE \varnothing 46**
Page 10

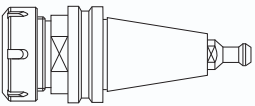

COLLET CHUCKS ISO 40
Page 10

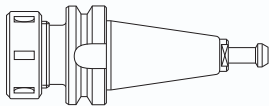

COLLET CHUCKS BT 30 - BT 35 - BT 40
Page 11

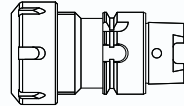

COLLET CHUCKS HSK-40A
Page 11

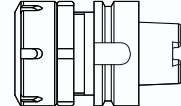

**COLLET CHUCKS HSK-63A WITH
RETURN RING NUT**
Page 11

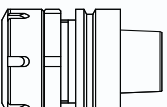

COLLET CHUCKS HSK-63F
Page 11

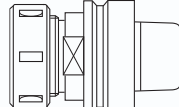

COLLET CHUCKS HSK-50F
Page 12

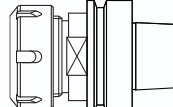

COLLET CHUCKS HSK-63F
Page 12

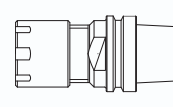

COLLET CHUCKS HSK-25E
Page 13

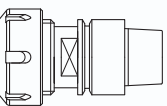

COLLET CHUCKS HSK-32E
Page 13

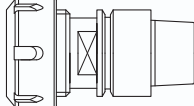

COLLET CHUCKS HSK-40E
Page 13

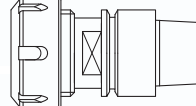

COLLET CHUCKS HSK-50E
Page 14

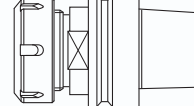

COLLET CHUCKS HSK-63E
Page 14

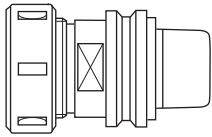

COLLET CHUCKS HSK-50E WITH FLANGE $\varnothing 40$
Pag. 14

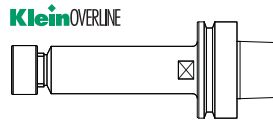

KleinOVERLINE
COLLET CHUCKS HSK-63F ER16 - G 2.5
BALANCING
Page 15

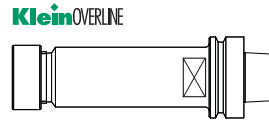

KleinOVERLINE
COLLET CHUCKS HSK-63F ER32 - G 2.5
BALANCING
Page 15

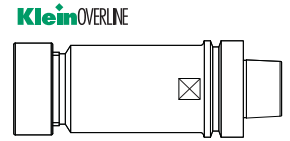

KleinOVERLINE
COLLET CHUCKS HSK-63F
DIN6388/EOC25 - G 2.5 BALANCING
Page 15

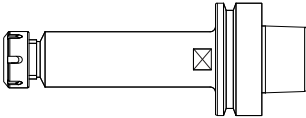

COLLET CHUCKS HSK-63F ER16 - G2.5
BALANCING
Pag. 16

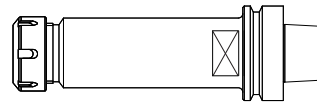

COLLET CHUCKS HSK-63F ER32 - G2.5
BALANCING
Page 16

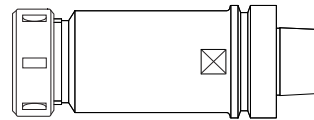

COLLET CHUCKS HSK-63F DIN6388/EOC25 -
G2.5 BALANCING
Page 16

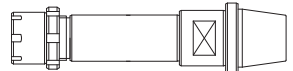

COLLET CHUCKS DIN 6499 (ER32)
FOR BACCI AND GREDA
Pag. 17

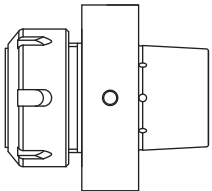

COLLET CHUCKS HSK-85 FOR WEING
Page 17

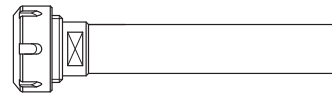

STRAIGHT SHANK TOOL EXTENSION
Page 17

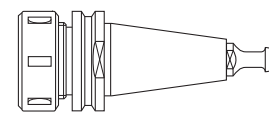

COLLET CHUCKS ISO 30 INOX
Page 18

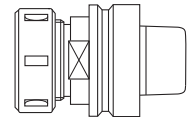

COLLET CHUCKS HSK-63F INOX
Page 18

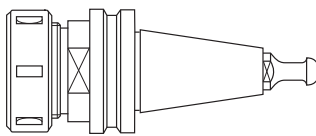

COLLET CHUCKS ISO 30 FOR MULTIAX
Page 19

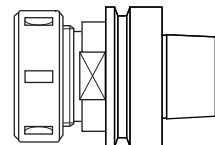

COLLET CHUCKS HSK-63F FOR MULTIAX
Page 19

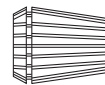

SPRING COLLETS ER 32 - DIN 6499
Page 21

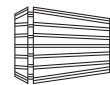

ULTRA PRECISION SPRING COLLETS
ER 32 - DIN 6499
Page 21



SPRING COLLET SET ER 32 - DIN 6499
Page 21

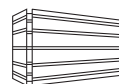

SPRING COLLETS ER 40 - DIN 6499
Page 22

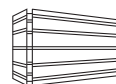

ULTRA PRECISION SPRING COLLETS
ER 40 - DIN 6499
Page 22



SPRING COLLET SET ER 40 - DIN 6499
Page 22

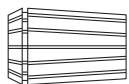

SPRING COLLETS EOC25 - DIN 6388 (462 E)
Page 22



SPRING COLLETS ER 25 - DIN 6499
Page 23



ULTRA PRECISION SPRING COLLETS
ER 25 - DIN 6499
Page 23



SPRING COLLET SET ER25 - DIN 6499
Page 23



SPRING COLLETS ER 20 - DIN 6499
Page 23



ULTRA PRECISION SPRING COLLETS
ER 20 - DIN 6499
Page 23



SPRING COLLETS ER 16 - DIN 6499
Page 24



ULTRA PRECISION SPRING COLLETS
ER 16 - DIN 6499
Page 24



SPRING COLLETS ER 11 - DIN 6499
Page 24

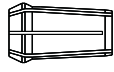

SPRING COLLETS EOC12 - DIN 6388 (407E)
Page 24



SPRING COLLETS EOC16 - DIN 6388 (415E)
Page 24

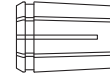

SPRING COLLETS 3° TAPER ANGLE FOR MULTIAX
Page 25

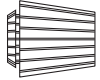

SPRING COLLETS ETS 32 - DIN 6499
Page 25

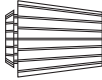

SPRING COLLETS ETS 40 - DIN 6499
Page 25



SPRING COLLET SET + WIPE OFF KIT
Page 25



SET IN WOODEN BOX
Page 26



SET IN PLASTIC BOX
Page 26



DUST & CHIP EXTRACTION NUT
Page 27



TORQUE WRENCHES FOR "MINI" NUTS
Page 28



TORQUE WRENCHES FOR "STANDARD" NUTS
Page 28



TORQUE HOOK WRENCHES
Page 28



TORQUE WRENCHES FOR "NO-NOISE" NUTS
Page 28



KEYS
Page 29



COLLET NUTS
Page 29

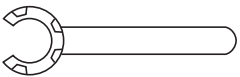

WRENCHES FOR COLLET NUT "MINI"
Page 29



DUST PLUG
Page 29



"NO-NOISE" COLLET NUTS
Page 29

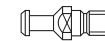

RETAINING PAWLS FOR CONCENTRIC CHUCK
Page 30

HotBlock®

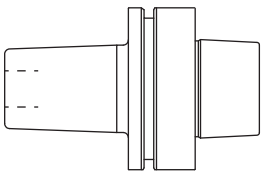

SHRINK FIT CHUCKS HSK-63F
Page 31

HotBlock®

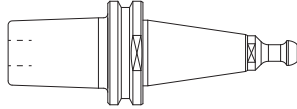

SHRINK FIT CHUCKS ISO 30
Page 31

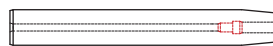

SHRINK FIT CHUCK EXTENSIONS L=150
Page 32



SHRINK FIT UNIT
Page 32



COOLING UNIT WITH AIR FLOW
Page 32

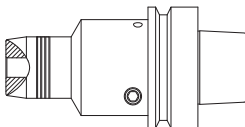

HSK63F HYDRO CHUCK
Page 33/34

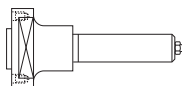

ADAPTERS FOR CIRCULAR SAWBLADES
Page 35

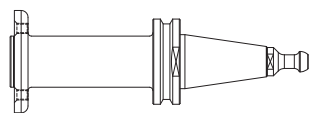

ISO 30 ADAPTERS FOR CIRCULAR SAWBLADES
Page 35

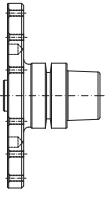

HSK-63E ADAPTORS FOR LARGE DIAMETER SAWBLADES
Page 35

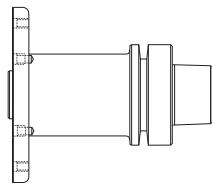

HSK-63 ADAPTORS FOR CIRCULAR SAWBLADES
Page 36



SECURITY FLANGE FOR SAW BLADES ADAPTORS
Page 36

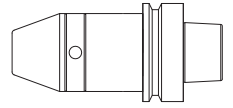

HSK-63F DRILL CHUCK FOR CNC
Page 37

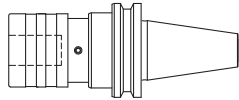

QUICK CHANGE ISO 30 TAPPING CHUCK
Page 37

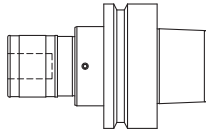

QUICK CHANGE HSK-63F TAPPING CHUCK
Page 37

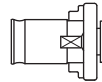

QUICK CHANGE BUSHES FOR TAPPING (DIN 371)
Page 38

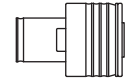

QUICK CHANGE BUSHES FOR TAPPING (DIN 371) WITH SAFETY CLUTCH
Page 38

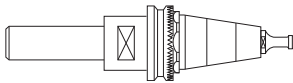

CUTTER ARBORS WITH ISO 30 TAPER
Page 39



CUTTER ARBORS WITH ISO 30 - ISO 40 TAPER
Page 39

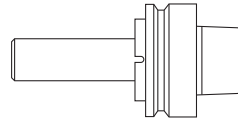

CUTTER ARBORS WITH HSK-63F TAPER
Page 40

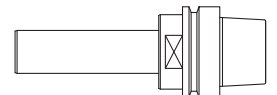

CUTTER ARBORS WITH HSK-63E TAPER
Page 41



LIFTING FLANGE FOR CUTTER ARBORS
Page 41

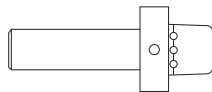

CUTTER ARBORS WITH HSK-85 TAPER
Page 42

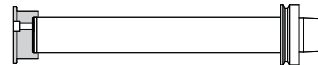

CUTTER ARBORS WITH HSK-85S TAPER
Page 42

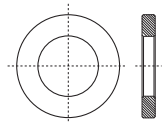

SPACERS 2-SIDES GRINDED
Page 43

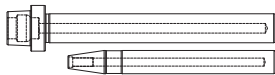

PRECISION TEST BARS
Page 44

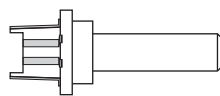

SPINDLE WIPERS
Page 45



COLLET WIPERS
Page 45



BRUSHES FOR COLLET BORE
Page 45



WIPE OFF KIT FOR CNC
Page 45

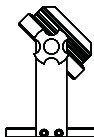

ADJUSTABLE DEMOUNT DEVICES
Page 46



DEMOUNT DEVICES FOR FLANGE Ø80 - Ø85
Page 46

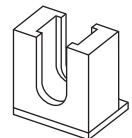

DEMOUNT DEVICES
Page 46



HW ROUTER BITS Z=2
Page 50



VHW ROUTER BITS Z=2
Page 50



SOLID CARBIDE SPIRAL CUTTERS, FINISH STYLE Z=1
Page 50



SOLID CARBIDE SPIRAL CUTTERS, FINISH STYLE Z=1
Page 50



SOLID CARBIDE SPIRAL CUTTERS,
FINISH STYLE Z=2
Page 51



SOLID CARBIDE SPIRAL CUTTERS FINISH
STYLE Z=2, **KleinDIA** COATED
Page 51



SOLID CARBIDE SPIRAL CUTTERS,
FINISH STYLE Z=2
Page 51



SOLID CARBIDE SPIRAL CUTTERS, FINISH
STYLE Z=3
Page 52



SOLID CARBIDE SPIRAL CUTTERS
FINISH STYLE Z=3, **KleinDIA** COATED
Page 52



SOLID CARBIDE SPIRAL CUTTERS,
FINISH STYLE Z=3
Page 52



SOLID CARBIDE SPIRAL CUTTERS,
ROUGHING STYLE Z=3
Page 53



SOLID CARBIDE SPIRAL CUTTERS
ROUGHING STYLE Z=3, **KleinDIA** COATED
Page 53



SOLID CARBIDE SPIRAL CUTTERS,
ROUGHING STYLE Z=3
Page 53



SOLID CARBIDE SPIRAL CUTTERS Z=3
RH ROTATION
Page 54



SOLID CARBIDE SPIRAL CUTTERS Z=3
LH ROTATION
Page 54



SOLID CARBIDE SPIRAL CUTTERS,
FINISH STYLE Z=1
Page 54



SOLID CARBIDE SPIRAL CUTTERS,
FINISH STYLE Z=2
Page 54



SOLID CARBIDE SPIRAL CUTTERS, FINISH
STYLE Z=2 **KleinDIA** COATED
Page 54



SOLID CARBIDE SPIRAL CUTTERS,
FINISH STYLE Z=2
Page 55



SOLID CARBIDE SPIRAL CUTTERS,
FINISH STYLE Z=3
Page 55



SOLID CARBIDE SPIRAL CUTTERS,
FINISH STYLE Z=3
Page 55



SOLID CARBIDE SPIRAL CUTTERS,
ROUGHING STYLE Z=3
Page 55



SOLID CARBIDE SPIRAL CUTTERS,
ROUGHING STYLE Z=3
Page 56



SOLID CARBIDE COMPRESSION
CUTTERS Z=1+1
Page 56



SOLID CARBIDE COMPRESSION
CUTTERS Z=1+1 **KleinDIA** COATED
Page 56



SOLID CARBIDE COMPRESSION
CUTTERS Z=1+1
Page 56



VHW STRAIGHT ROUTER BITS
FOR NESTING Z=3
Page 56



SOLID CARBIDE COMPRESSION
CUTTERS Z=2+2
Page 56



SOLID CARBIDE COMPRESSION
CUTTERS Z=2+2
Page 57



SOLID CARBIDE COMPRESSION
CUTTERS Z=2+2 **KleinDIA** COATED
Page 57



SOLID CARBIDE MORTISE COMPRESSION
CUTTERS Z=2+2
Page 57



SOLID CARBIDE MORTISE COMPRESSION
CUTTERS Z=2+2 **KleinDIA** COATED
Page 57



SOLID CARBIDE COMPRESSION
CUTTERS Z=3+3
Page 58



SOLID CARBIDE COMPRESSION
CUTTERS Z=3+3 **KleinDIA** COATED
Page 58



SOLID CARBIDE MORTISE COMPRESSION
CUTTERS Z=3+3
Page 58



SOLID CARBIDE MORTISE COMPRESSION
CUTTERS Z=3+3 **KleinDIA** COATED
Page 58



SOLID CARBIDE SPIRAL CUTTERS FOR
LOCK-CASE Z=2 - Z=3
Page 59



SOLID CARBIDE SPIRAL CUTTERS FOR
LOCK-CASE Z=3, **KleinDIA** COATED
Page 59



SOLID CARBIDE SPIRAL CUTTERS Z=3
FOR LOCKS
Page 59



SOLID CARBIDE SPIRAL
CUTTERS Z=2
Page 59



SOLID CARBIDE SPIRAL CUTTERS Z=2
Page 60



SOLID CARBIDE SPIRAL CUTTERS,
UPCUT FINISH STYLE Z=2
Page 60



SOLID CARBIDE SPIRAL CUTTERS,
DOWNCUT FINISH STYLE Z=2
Page 60



SOLID CARBIDE SPIRAL CUTTERS,
UPCUT FINISH STYLE Z=2
Page 60



SOLID CARBIDE SPIRAL CUTTERS,
FINISH STYLE Z=2
Page 60



SOLID CARBIDE COMPRESSION
CUTTERS Z=2+2 WITH DOUBLE BALL
BEARING
Page 61



HW FLUSH TRIM BITS WITH DOUBLE
BALL BEARINGS Z=2
Page 61



SOLID CARBIDE SPIRAL CUTTERS
"LAMELLO" **KleinDIA** COATED
Page 61



SOLID CARBIDE SPIRAL CUTTERS,
ROUGHING STYLE Z=2
Page 61



SOLID CARBIDE SPIRAL CUTTERS,
ROUGHING STYLE Z=2
Page 62



SOLID CARBIDE TAPERED BALL NOSE
SPIRAL BITS Z=3
Page 62



SOLID CARBIDE SPIRAL CUTTERS
RADIUS STYLE Z=2
Page 62



HS ROUTER BITS FOR "HUNDEGGER"
MACHINES
Page 62



SOLID CARBIDE SPIRAL ROUTER BITS
FINISH/ROUGHING STYLE
KleinDIA COATED
Page 63















SOLID CARBIDE SPIRAL ROUTER BITS
FINISH/ROUGHING STYLE **KleinDIA** COATED
Page 63



TOOL KIT FOR CNC ROUTERS
Page 64

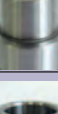
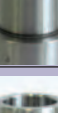

TOOL KIT FOR CNC ROUTERS
Page 65

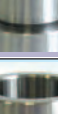
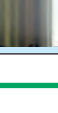
Type of toolholder		COLLET CHUCKS FOR SHANK CUTTERS							
		ER16	ER20	ER25	ER32	ER40	EOC12	EOC16	EOC25
	COLLET CHUCKS MORSE				Page 7				
	COLLET CHUCKS CYL				Page 7		Page 7		
	ISO30	Page 8	Page 8	Page 8	Page 7-8 9-10 7.23	Page 8-9 10-18			Page 9
	ISO40				Page 10	Page 10			
	BT30 - BT 35 - BT40				Page 11	Page 11			
	HSK-40A			Page 11	Page 11				
	HSK-63A					Page 11			
	HSK-50F	Page 12		Page 12	Page 12	Page 12			Page 12
	HSK-63F	Page 7.20 7.21		Page 12	Page 12-15 16-18	Page 11-12 18			Page 12-15 16-18
	HSK-25E	Page 13							
	HSK-32E		Page 13	Page 13					
	HSK-40E			Page 13	Page 13				
	HSK-50E			Page 14	Page 14				Page 14
	HSK-63E				Page 14	Page 14			
	HSK85					Page 17			

SHRINK FIT CHUCKS		DRILL CHUCK	SAW ADAPTORS	ARBORS						TAPPING CHUCK	DEMOUNT DEVICES
mm	inches			Ø1"	Ø30	Ø1-1/4"	Ø35	Ø40	Ø50		
			Page 35								
Page 31			Page 35		Page 39					Page 37	Page 46
											Page 46
											Page 46
											Page 46
											Page 46
											Page 46
											Page 46
Page 31	Page 31	Page 37	Page 36	Page 40	Page 40	Page 40	Page 40	Page 40		Page 37	Page 46
											Page 46
											Page 46
											Page 46
			Page 36-36		Page 41		Page 41	Page 41			Page 46
					Page 42		Page 42	Page 42	Page 42		Page 46

TOOL HOLDERS



THE HOLLOW TAPER SHANK IS PRODUCED ACCORDING TO DIN69893, ISO OR JIS STANDARDS WITH ACCURACY OF HSK-F SHANKS LOWER THAN A72

A DEDICATED POCKET INSIDE THE TAPER TO INSTALL BALLUFF/RFID CHIP

MAXIMUM ERROR OF CONCENTRICITY BETWEEN THE CONICAL PART AND THE TOOL'S SEAT OF 0.003 MM (RUNOUT: 0.0001")

TO ACHIEVE THE MAXIMUM LEVEL OF PRECISION, ALL OUR TOOL HOLDERS ARE MANUFACTURED BY HARD TURNING MACHINE AND THEN ALL THOROUGHLY PRECISION GROUNDED BOTH ON SHANK, OUTSIDE PART OF TAPER AND COLLET NUT THREADS

THE SPECIAL STEEL USED TO PRODUCE OUR TOOL HOLDERS HAVE A HARDNESS OF 58+2 HRC ON THE ROCKWELL HARDNESS SCALE WITH A DEPTH OF 0.8/1 MM

ALL OUR TOOL HOLDERS ARE LASER MARKED FOLLOWING EUROPEAN SAFETY REGULATIONS

THE BALL BEARING CLAMPING NUT IMPROVES THE CLAMPING PRECISION THANKS TO A HOMOGENEOUS CLAMPING FORCE. IT CAN BE USED BOTH FOR THE RIGHT-HAND AND LEFT-HAND ROTATION

QUALITY CONTROL

SISTEMI has always been known for the high quality of the products offered. Keywords of this success are the **attention to production materials** and the use of the most modern construction techniques together with more accurate controls and the continuous research of innovative products. Each toolholder is supplied packed in a carton box with internal sheet of guarantee inside.

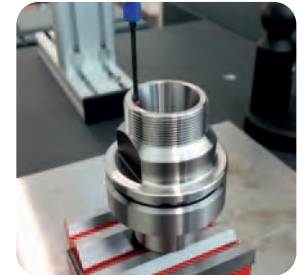

MAINTENANCE

A regular and **proper cleaning** of mechanical components is critical to avoid jamming during processing operations and the consequent risk of a poor finishing of the piece or even tool breakage. The worked pieces leave impurities and debris in the collets holes, in the seats of tool holders or electrospindles. These should be therefore cleaned daily using the **right wipers** (see items T137 and X137 at page 7.40)



USEFUL INFORMATION

- 1) The collect chuck may be used only on router machines and machining centers for processing wood and wood-based material with comparable cutting characteristics.
- 2) The instructions of the machine manufacturer regarding the suitability of the clamping device have to be observed.
- 3) The direction of rotation marked on the clamping device has to be observed and followed. The direction of rotation of the tool and the collet chuck has to be the same.
- 4) Do not exceed the maximum RPM "n max" marked on the collet chuck. The maximum RPM of the system is determined by the tool, if the RPM of the tool is lower than that of the chuck.



SAFETY NORMS

Table 1.1:
Calculation of the minimum clamping length (Safety regulation EN847-1).

On the tool shank the minimum clamping length is marked.
The shank has to be clamped as far as possible, but at least up to the marking of the minimum clamping length (K).
The free shank length (Lo) should be as short as possible, granting a higher rigidity and smaller risk of tool breakage.

Shank diameter S (mm)	Min. clamping length K (mm)
$S \leq 10$	$K \geq 20$
$10 < S < 25$	$K = S \times 2$
$S \geq 25$	$K = S \times 1,8$

WRONG ASSEMBLING

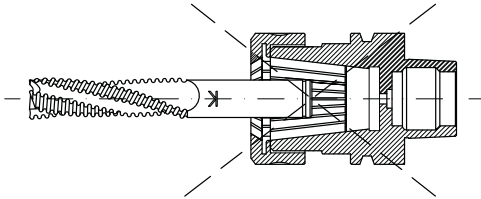

OPTIMIZED CLAMPING LENGTH

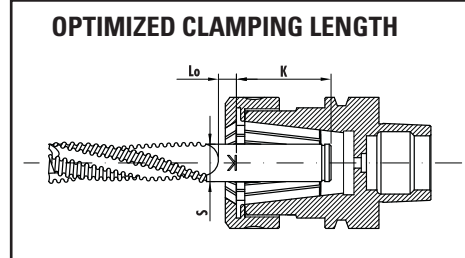

WRONG ASSEMBLING

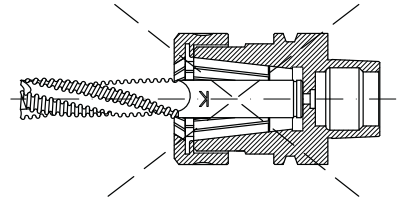

Safety norm for the calculation of the minimum clamping length

D = Tool diameter
B = Maximum safe length of the tool
S = Shank diameter

COLLET CHUCKS ISO30

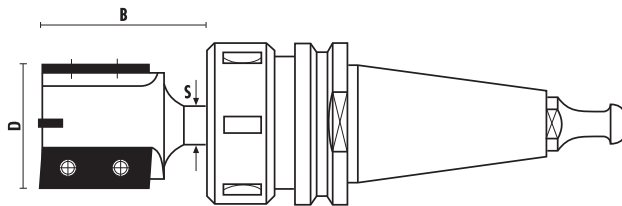

COLLET CHUCKS HSK63F

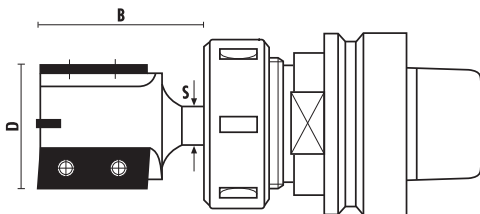

In order to avoid the risk of tool breakage during the job, make sure you answered the following questions:

- 1- Are you using the proper tool for the desired job?
- 2- Collets and tool holders are clean and the tool is inserted properly?
- 3- RPM and feed speed are correct?
- 4- Is the depth cut not too excessive for the material processed?
- 5- Are there any evident vibrations of the mechanical parts?
- 6- No right answer to your problem?
Stop running parts and check with your "Klein" distributor.

If you have to contact your distributor of technical support, please have ready the following information:

- a- Type of machine being used
- b- Type of material being cut
- c- Part number of tool, "Klein" item
- d- RPM/feed speed/depth of cut
- e- How long did the tool worked before it broke/damaged?
- f- Have you already done this operation in the past using the same tool?

Table 2.1

D (mm)	S (mm)																	
	Ø 6	Ø 8	Ø 10	Ø 12	Ø 14	Ø 16	Ø 18	Ø 20	Ø 25									
6	81																	
8	66	94																
10	59	82	105															
12	53	73	94	115														
14	48	66	85	105	124													
16	44	61	78	96	114	133												
18	41	57	73	89	106	123	140											
20	38	53	68	84	99	115	132	148										
25		45	59	72	86	100	114	129	153									
30			40	52	64	77	89	102	115	125								
35				47	58	69	81	92	104	106								
40					43	53	64	74	85	91	92							
45						49	59	68	78	80	81							
50							46	55	64	71	71	73						
55								51	60	64	64	66						
60									48	56	58	59	60					
65										46	52	53	54	56				
70											48	49	50	52				
75												46	47	49	51			
80													47	47	51			
85														47	51			
90															47	50		
95																47	50	
100																	47	50
105																		49
110																		49

Table 2.2

D (mm)	S (mm)																	
	Ø 6	Ø 8	Ø 10	Ø 12	Ø 14	Ø 16	Ø 18	Ø 20	Ø 25									
6	81																	
8	68	94																
10	59	82	105															
12	53	73	94	115														
14	48	66	85	105	124													
16	44	61	78	96	114	133												
18	41	57	73	89	106	123	140											
20	38	53	68	84	99	115	132	148										
25		45	59	72	86	100	114	129	165									
30			40	52	64	77	89	102	115	147								
35				47	58	69	81	92	104	133								
40					43	53	64	74	85	95	123							
45						49	59	68	78	88	114							
50							46	55	64	73	83	106						
55								51	60	69	78	100						
60									48	56	65	73	94					
65										46	53	61	69	90				
70											51	59	66	85				
75												48	55	63	82			
80													53	60	78			
85														51	58	75		
90															49	56	72	
95																47	50	
100																	47	50
105																		49
110																		49

Table 2.1: Method for the calculation of the measure B for collet chucks ISO30

Table 2.2: Method for the calculation of the measure B for collet chucks HSK63F

CONCENTRIC CHUCKS S=MK2

ART. T116

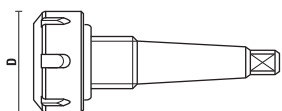

- Wrench art. Z052.301.N
- Spare parts see page 10.07
- Supplied with nut (without collet)

Item	D	Shank	Clamping nut
T116.100.R	40	C.M. 2/FIL M20	Z091.000.R
T116.100.L	40	C.M. 2/FIL M20	Z091.000.L

CONCENTRIC CHUCKS

ART. T116 - X116

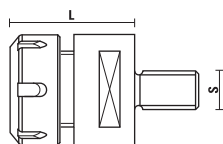

Item X116
Set in wooden box

- Wrench art. Z052.301.N
- Spare parts see page 10.07
- With spare collets Art. T117
- To use on spindle moulder
- Supplied with nut (without collet)

RH rotation	S	L	Clamping nut
T116.500.R	M16	42	Z091.000.R
T116.501.R	M14	42	Z091.000.R
T116.502.R	M18	42	Z091.000.R
T116.503.R	M20	42	Z091.000.R

X116.500.R	Set with chuck M16 + 3 spring collets \varnothing 6/8/12 (See item T117)
X116.501.R	Set with chuck M14 + 3 spring collets \varnothing 6/8/12
X116.502.R	Set with chuck M18 + 3 spring collets \varnothing 6/8/12
X116.503.R	Set with chuck M20 + 3 spring collets \varnothing 6/8/12

SPRING COLLETS

ART. T117

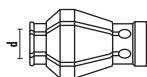

For Art. T116

Item	d
T117.060.N	\varnothing 6
T117.064.N	\varnothing 6,4
T117.080.N	\varnothing 8
T117.090.N	\varnothing 9
T117.095.N	\varnothing 9,5
T117.100.N	\varnothing 10
T117.110.N	\varnothing 11
T117.120.N	\varnothing 12
T117.127.N	\varnothing 12,7
T117.130.N	\varnothing 13
T117.140.N	\varnothing 14

COLLET CHUCKS MORSE TAPER

ART. T118

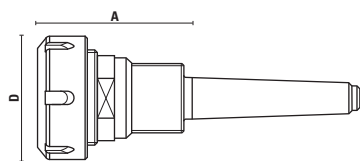

- Supplied with nut (without collet)
- Threaded nut and wrenches see page 7.33, spring collets see page 7.26
- Threaded nut DIN 6499
- The "A" measure will be determined with clamped tool shanks by using our spring collet DIN6499. The "A" measure may be subject to variations depending on the diameter of the clamped tools.

Item	Shank	A	D	Spring collets	Clamping nut	Rot.
T118.200.R	MK2 / FIL. M30	70	50	∅ 2÷20 (Art. T119/ER32)	Z091.001.R	RH
T118.200.L	MK2 / FIL. M30	70	50	∅ 2÷20 (Art. T119/ER32)	Z091.001.L	LH
T118.202.R	MK2 / FIL. M30	70	50	∅ 2÷20 (Art. T119/ER32)	Z091.101.R ball bearing nut	RH/LH
T118.300.R	MK3 / FIL. M30	70	50	∅ 2÷20 (Art. T119/ER32)	Z091.001.R	RH
T118.300.L	MK3 / FIL. M30	70	50	∅ 2÷20 (Art. T119/ER32)	Z091.001.L	LH
T118.302.R	MK3 / FIL. M30	70	50	∅ 2÷20 (Art. T119/ER32)	Z091.101.R ball bearing nut	RH/LH

COLLET CHUCKS CYL SHANK ∅ 20

ART. T118

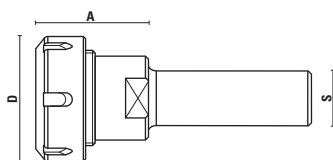

- Supplied with nut (without collet)
- Threaded nut and wrenches see page 7.33, spring collets see page 7.26
- Threaded nut DIN 6499
- The "A" measure will be determined with clamped tool shanks by using our spring collet DIN6499. The "A" measure may be subject to variations depending on the diameter of the clamped tools.

Item	S	A	D	Spring collets	Clamping nut	Rot.
T118.400.R	20	51	50	∅ 2÷20 (Art. T119/ER32)	Z091.001.R	RH
T118.402.R	20	51	50	∅ 2÷20 (Art. T119/ER32)	Z091.101.R ball bearing nut	RH/LH

COLLET CHUCKS CYL SHANK ∅ 25

ART. T118

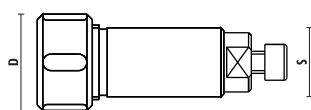

- Supplied with nut (without collet)
- Threaded nut and wrenches see page 7.31, spring collets see page 7.29
- Threaded nut DIN 6388/EOC12

For: **Weeke, BHX** machines

Item	S	D	Spring collets	Clamping nut	Rot.
T118.580.R	25	35	∅ 1÷12,7 (Art. T136/EOC12)	Z091.205.R	RH

COLLET CHUCKS ISO 30 TAPERED FLANGE

ART. T118

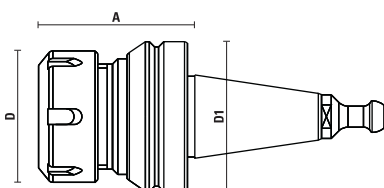

RPM
24.000

T139.157.N

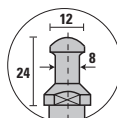

- Supplied with nut (without collet) and retaining pawl
- Threaded nut and wrenches see page 7.33, spring collets see page 7.26
- Threaded nut DIN 6499
- The "A" measure will be determined with clamped tool shanks by using our spring collet DIN6499. The "A" measure may be subject to variations depending on the diameter of the clamped tools.

Item T118.891.R for: **Thermwood**

Item	A	D	D1	Spring collets	Clamping nut	Rot.
T118.680.R	58	50	57	∅ 2÷20 (Art. T119/ER32)	Z091.001.R	RH

COLLET CHUCKS ISO 30 SCM/MORBIDELLI

ART. T118

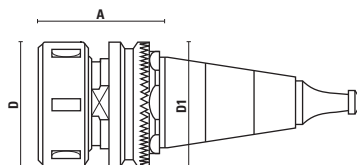

- Supplied with nut (without collet) and retaining pawl
- Threaded nut and wrenches see page 7.33, spring collets see page 7.26, 7.27
- Threaded nut DIN 6499
- Threaded nut DIN 6388/EOC25
- The "A" measure will be determined with clamped tool shanks by using our spring collet DIN6499 - DIN 6388/EOC25. The "A" measure may be subject to variations depending on the diameter of the clamped tools

RPM
24.000

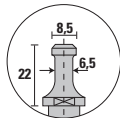

Item T118.790.R for:
Morbidelli, SCM

With anti-adherent surface treatment "Impreglon"

Item	Taper	A	D	D1	Spring collets	Clamping nut	Rot.
T118.700.R	ISO 30	55	50	49	Ø 2÷20 (Art. T119/ER32)	Z091.001.R	RH
T118.702.R	ISO 30	55	50	49	Ø 2÷20 (Art. T119/ER32)	Z091.101.R ball bearing nut	RH/LH
T118.701.R	ISO 30	71	60	49	Ø 2÷25 (Art. T124/EOC25)	Z091.203.R ball bearing nut	RH/LH
T118.711.R	ISO 30	71	60	49	Ø 2÷25 (Art. T124/EOC25)	Z091.202.R	RH
T118.711.L selling out	ISO 30	71	60	49	Ø 2÷25 (Art. T124/EOC25)	Z091.202.L	LH

COLLET CHUCKS ISO 30

ART. T118

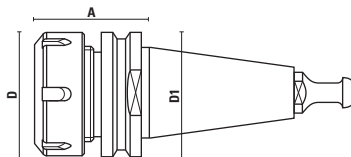

- Supplied with nut (without collet) and retaining pawl
- Threaded nut and wrenches see page 7.33, spring collets see page 7.26, 7.27, 7.28, 7.29
- Threaded nut DIN 6499
- The "A" measure will be determined with clamped tool shanks by using our spring collet DIN6499. The "A" measure may be subject to variations depending on the diameter of the clamped tools.

RPM
24.000

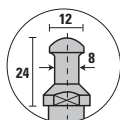

Item T118.891.R for: **Biesse** (after 09/09/92), **HSD spindle**, **Masterwood - Bulleri, Vitap, Hiteco**

Item	Taper	A	D	D1	Spring collets	Clamping nut	Rot.
T118.796.R	ISO 30	50	32	50	Ø 2÷10 (Art. T127/ER16)	Z091.105.R	RH
T118.797.R	ISO 30	50	35	50	Ø 2÷12 (Art. T126/ER20)	Z091.104.R	RH
T118.798.R	ISO 30	50	42	50	Ø 1÷16 (Art. T125/ER25)	Z091.103.R	RH
T118.800.R	ISO 30	50	50	50	Ø 2÷20 (Art. T119/ER32)	Z091.001.R	RH
T118.800.L	ISO 30	50	50	50	Ø 2÷20 (Art. T119/ER32)	Z091.001.L	LH
T118.802.R	ISO 30	50	50	50	Ø 2÷20 (Art. T119/ER32)	Z091.101.R ball bearing nut	RH/LH
T118.830.R	ISO 30	60	63	50	Ø 2÷30 (Art. T123/ER40)	Z091.002.R	RH
T118.830.L	ISO 30	60	63	50	Ø 2÷30 (Art. T123/ER40)	Z091.002.L	LH
T118.832.R	ISO 30	60	63	50	Ø 2÷30 (Art. T123/ER40)	Z091.102.R ball bearing nut	RH/LH

EXTENDED COLLET CHUCKS ISO 30

ART. T118

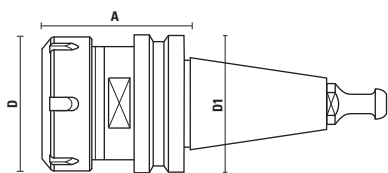

- Supplied with nut (without collet) and retaining pawl
- Threaded nut and wrenches see page 7.33, spring collets see page 7.26, 7.27
- Threaded nut DIN 6499
- The "A" measure will be determined with clamped tool shanks by using our spring collet DIN6499. The "A" measure may be subject to variations depending on the diameter of the clamped tools.

RPM
24.000

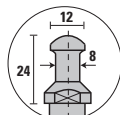

Item T118.891.R for: **Biesse** (after 09/09/92), **HSD spindle**, **Masterwood - Bulleri, Vitap, Hiteco**

Item	Taper	A	D	D1	Spring collets	Clamping nut	Rot.
T118.804.R	ISO 30	68	50	50	Ø 2÷20 (Art. T119/ER32)	Z091.001.R	RH
T118.804.L	ISO 30	68	50	50	Ø 2÷20 (Art. T119/ER32)	Z091.001.L	LH
T118.806.R	ISO 30	68	50	50	Ø 2÷20 (Art. T119/ER32)	Z091.101.R ball bearing nut	RH/LH
T118.834.R	ISO 30	68	63	50	Ø 2÷30 (Art. T123/ER40)	Z091.002.R	RH
T118.834.L	ISO 30	68	63	50	Ø 2÷30 (Art. T123/ER40)	Z091.002.L	LH
T118.836.R	ISO 30	68	63	50	Ø 2÷30 (Art. T123/ER40)	Z091.102.R ball bearing nut	RH/LH
T118.838.R	ISO 30	68	60	50	Ø 2÷25 (Art. T124/EOC25)	Z091.202.R	RH
T118.839.R	ISO 30	68	60	50	Ø 2÷25 (Art. T124/EOC25)	Z091.203.R ball bearing nut	RH/LH

RPM
24.000

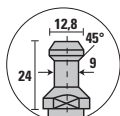

Item T118.792.R for: **Alberti, Vitap, Masterwood** (motor G. Colombo)

Item	Taper	A	D	D1	Spring collets	Clamping nut	Rot.
T118.810.R	ISO 30	68	50	50	Ø 2÷20 (Art. T119/ER32)	Z091.001.R	RH
T118.810.L	ISO 30	68	50	50	Ø 2÷20 (Art. T119/ER32)	Z091.001.L	LH
T118.812.R	ISO 30	68	50	50	Ø 2÷20 (Art. T119/ER32)	Z091.101.R ball bearing nut	RH/LH
T118.814.R	ISO 30	68	63	50	Ø 2÷30 (Art. T123/ER40)	Z091.002.R	RH
T118.814.L	ISO 30	68	63	50	Ø 2÷30 (Art. T123/ER40)	Z091.002.L	LH
T118.816.R	ISO 30	68	63	50	Ø 2÷30 (Art. T123/ER40)	Z091.102.R ball bearing nut	RH/LH

RPM
24.000

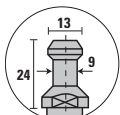

Item T118.791.R for: **Anderson, Busellato, Weeke, Ima, Bulleri, Maka, Cosmec, Reichenbacher**

Item	Taper	A	D	D1	Spring collets	Clamping nut	Rot.
T118.820.R	ISO 30	68	50	50	Ø 2÷20 (Art. T119/ER32)	Z091.001.R	RH
T118.820.L	ISO 30	68	50	50	Ø 2÷20 (Art. T119/ER32)	Z091.001.L	LH
T118.822.R	ISO 30	68	50	50	Ø 2÷20 (Art. T119/ER32)	Z091.101.R ball bearing nut	RH/LH
T118.824.R	ISO 30	68	63	50	Ø 2÷30 (Art. T123/ER40)	Z091.002.R	RH
T118.824.L	ISO 30	68	63	50	Ø 2÷30 (Art. T123/ER40)	Z091.002.L	LH
T118.826.R	ISO 30	68	63	50	Ø 2÷30 (Art. T123/ER40)	Z091.102.R ball bearing nut	RH/LH
T118.828.R	ISO 30	68	60	50	Ø 2÷25 (Art. T124/EOC25)	Z091.202.R	RH
T118.829.R	ISO 30	68	60	50	Ø 2÷25 (Art. T124/EOC25)	Z091.203.R ball bearing nut	RH/LH

COLLET CHUCKS ISO 30 WITH FLANGE Ø 58

ART. T118

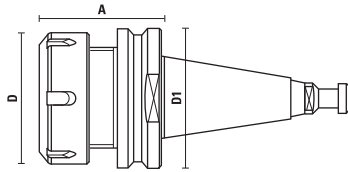

RPM
24.000

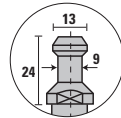

- Supplied with nut (without collet) and retaining pawl
- Threaded nut and wrenches see page 7.33, spring collets see page 7.26, 7.27
- Threaded nut DIN 6499
- The "A" measure will be determined with clamped tool shanks by using our spring collet DIN6499. The "A" measure may be subject to variations depending on the diameter of the clamped tools.

Item T118.791.R for:
electrospindles **Anderson, Elte**

Item	Taper	A	D	D1	Spring collets	Clamping nut	Rot.
T118.845.R	ISO 30	50	50	58	Ø 2÷20 (Art. T119/ER32)	Z091.001.R	RH
T118.846.R	ISO 30	50	50	58	Ø 2÷20 (Art. T119/ER32)	Z091.101.R ball bearing nut	RH/LH
T118.847.R	ISO 30	56	63	58	Ø 2÷30 (Art. T123/ER40)	Z091.002.R	RH
T118.848.R	ISO 30	56	63	58	Ø 2÷30 (Art. T123/ER40)	Z091.102.R ball bearing nut	RH/LH

RPM
24.000

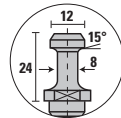

Item T118.793.R for:
Esseteam (solid flange)

Item	Taper	A	D	D1	Spring collets	Clamping nut	Rot.
T118.861.R	ISO 30	50	50	58	Ø 2÷20 (Art. T119/ER32)	Z091.001.R	RH
T118.862.R	ISO 30	50	50	58	Ø 2÷20 (Art. T119/ER32)	Z091.101.R ball bearing nut	RH/LH
T118.864.R	ISO 30	56	63	58	Ø 2÷30 (Art. T123/ER40)	Z091.002.R	RH
T118.866.R	ISO 30	56	63	58	Ø 2÷30 (Art. T123/ER40)	Z091.102.R ball bearing nut	RH/LH

COLLET CHUCKS ISO 30 WITH FLANGE Ø 46

ART. T118

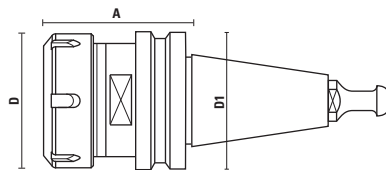

RPM
24.000

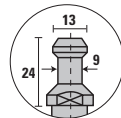

- Supplied with nut (without collet) and retaining pawl
- Threaded nut and wrenches see page 7.33, spring collets see page 7.26, 7.27, 7.30
- Threaded nut DIN 6499
- The "A" measure will be determined with clamped tool shanks by using our spring collet DIN6499. The "A" measure may be subject to variations depending on the diameter of the clamped tools.

Item T118.794.R for:
CMS (flange Ø 46)

Item	Taper	A	D	D1	Spring collets	Clamping nut	Rot.
T118.880.R	ISO 30	52	50	46	Ø 2÷20 (Art. T134/ETS32)	Z091.301.R	RH
T118.881.R	ISO 30	52	50	46	Ø 2÷20 (Art. T119/ER32)	Z091.001.R	RH
T118.882.R	ISO 30	57	63	46	Ø 2÷25 (Art. T135/ETS40)	Z091.302.R	RH
T118.883.R	ISO 30	57	63	46	Ø 2÷25 (Art. T123/ER40)	Z091.002.R	RH

COLLET CHUCKS ISO 40

ART. T118

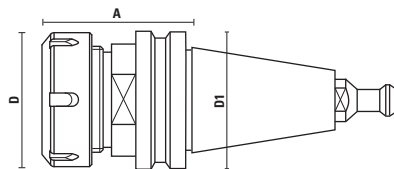

RPM
24.000

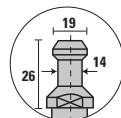

- Supplied with nut (without collet) and retaining pawl
- Threaded nut and wrenches see page 7.33, spring collets see page 7.26, 7.27
- Threaded nut DIN 6499
- The "A" measure will be determined with clamped tool shanks by using our spring collet DIN6499. The "A" measure may be subject to variations depending on the diameter of the clamped tools.

Item T118.893.R for:
IMA, Weeke, Maka, Reichenbacher, Stegherr

Item	Taper	A	D	D1	Spring collets	Clamping nut	Rot.
T118.850.R	ISO 40	73	50	63,5	Ø 2÷20 (Art. T119/ER32)	Z091.001.R	RH
T118.852.R	ISO 40	73	50	63,5	Ø 2÷20 (Art. T119/ER32)	Z091.101.R ball bearing nut	RH/LH
T118.870.R	ISO 40	73	63	63,5	Ø 2÷30 (Art. T123/ER40)	Z091.002.R	RH
T118.872.R	ISO 40	73	63	63,5	Ø 2÷30 (Art. T123/ER40)	Z091.102.R ball bearing nut	RH/LH

COLLET CHUCKS BT 30 - BT 35 - BT 40

ART. T118

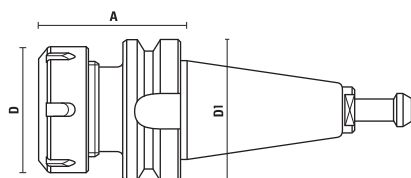

RPM
24.000

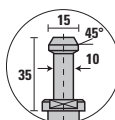
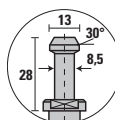
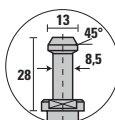
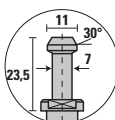

- Supplied with nut (without collet) and retaining pawl
- Threaded nut and wrenches see page 7.33, spring collets see page 7.26, 7.27
- Threaded nut DIN 6499
- The "A" measure will be determined with clamped tool shanks by using our spring collet DIN6499. The "A" measure may be subject to variations depending on the diameter of the clamped tools

- Item T118.895.R for: BT 30 **Shoda**
- Item T118.896.R for: BT 35 **Heian (1)**
- Item T118.896.R030 for: BT 35 **Heian (2)**
- Item T118.897.R for: BT 40 **Shoda**

Item	Taper	A	D	D1	Spring collets	Clamping nut	Rot.
T118.910.R	BT 30	60	50	46	∅ 2÷20 (Art. T119/ER32)	Z091.101.R ball bearing nut	RH/LH
T118.912.R	BT 30	70	63	46	∅ 2÷30 (Art. T123/ER40)	Z091.102.R ball bearing nut	RH/LH
T118.920.R	BT 35 (1)	69	50	53	∅ 2÷20 (Art. T119/ER32)	Z091.101.R ball bearing nut	RH/LH
T118.921.R	BT 35 (2)	69	50	53	∅ 2÷20 (Art. T119/ER32)	Z091.101.R ball bearing nut	RH/LH
T118.922.R	BT 35 (1)	60	63	53	∅ 2÷30 (Art. T123/ER40)	Z091.102.R ball bearing nut	RH/LH
T118.923.R	BT 35 (2)	60	63	53	∅ 2÷30 (Art. T123/ER40)	Z091.102.R ball bearing nut	RH/LH
T118.930.R	BT 40	65	50	63	∅ 2÷20 (Art. T119/ER32)	Z091.101.R ball bearing nut	RH/LH

COLLET CHUCKS HSK-40A

ART. T118

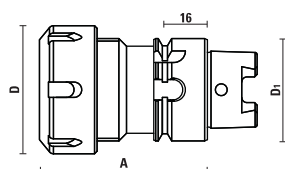

RPM
24.000



BALLUFF
POCKET

- The hollow taper shank is produced according to DIN69893
- Supplied with nut (without collet)
- Threaded nut and wrenches see page 7.33, spring collets see page 7.26, 7.28
- Threaded nut DIN 6499
- The "A" measure will be determined with clamped tool shanks by using our spring collet DIN6499. The "A" measure may be subject to variations depending on the diameter of the clamped tools

- For "Centaurio"

Item	Taper	A	D	D1	Spring collets	Clamping nut	Rot.
T118.950.R	HSK-40A	65	50	40	∅ 2÷20 (Art. T119/ER32)	Z091.001.R	RH
T118.951.R NEW	HSK-40A	65	42	40	∅ 1÷16 (Art. T125/ER25)	Z091.103.R	RH

COLLET CHUCKS HSK-63A WITH RETURN RING NUT

ART. T118

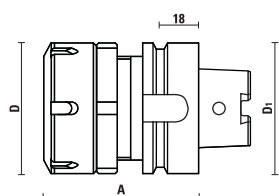

RPM
24.000



BALLUFF
POCKET

- The hollow taper shank is produced according to DIN69893
- Supplied with nut (without collet) and return ring nut
- Threaded nut and wrenches see page 7.33, spring collets see page 7.27
- Threaded nut DIN 6499
- The "A" measure will be determined with clamped tool shanks by using our spring collet DIN6499. The "A" measure may be subject to variations depending on the diameter of the clamped tools

- For "Essetre"

Item	Taper	A	D	D1	Spring collets	Clamping nut	Return ring nut	Rot.
T118.956.R	HSK-63A	71	63	63	∅ 2÷30 (Art. T123/ER40)	Z091.002.R	Z091.902.R	RH

COLLET CHUCKS HSK-63F

ART. T118

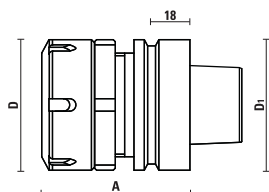

RPM
24.000



BALLUFF
POCKET

- The hollow taper shank is produced according to DIN69893
- Supplied with nut (without collet) and return ring nut
- Threaded nut and wrenches see page 7.33, spring collets see page 7.27
- Threaded nut DIN 6499
- The "A" measure will be determined with clamped tool shanks by using our spring collet DIN6499. The "A" measure may be subject to variations depending on the diameter of the clamped tools

- For "Essetre"

Item	Taper	A	D	D1	Spring collets	Clamping nut	Return ring nut	Rot.
T118.953.R	HSK-63F	71	63	63	∅ 2÷30 (Art. T123/ER40)	Z091.102.R	Z091.902.R	RH

- For "Uniteam"

Item	Taper	A	D	D1	Spring collets	Clamping nut	Return ring nut	Rot.
T118.959.R	HSK-63F	79	63	63	∅ 2÷30 (Art. T123/ER40)	Z091.002.R	Z091.902.R	RH

COLLET CHUCKS HSK-50F

ART. T118

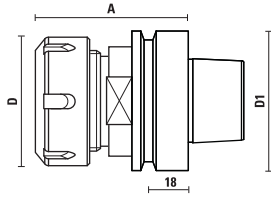

- The hollow taper shank is produced according to DIN69893
- Supplied with nut (without collet)
- Threaded nut and wrenches see page 7.33, spring collets see page 7.27, 7.28, 7.29
- Threaded nut DIN 6499
- Threaded nut DIN 6388 (EOC25)
- The "A" measure will be determined with clamped tool shanks by using our spring collet DIN6499 - DIN 6388/EOC25. The "A" measure may be subject to variations depending on the diameter of the clamped tools



Item	Taper	A	D	D1	Spring collets	Clamping nut	Rot.
T118.960.R NEW	HSK-50F	70	32	50	∅ 1÷10 (Art. T127/ER16)	Z091.105.R	RH
T118.962.R	HSK-50F	60	42	50	∅ 1÷16 (Art. T125/ER25)	Z091.103.R	RH
T118.966.R	HSK-50F	73	50	50	∅ 2÷20 (Art. T119/ER32)	Z091.001.R	RH
T118.968.R	HSK-50F	76	50	50	∅ 2÷20 (Art. T119/ER32)	Z091.101.R ball bearing nut	RH/LH
T118.970.R	HSK-50F	76	63	50	∅ 2÷30 (Art. T123/ER40)	Z091.002.R	RH
T118.972.R	HSK-50F	78	63	50	∅ 2÷30 (Art. T123/ER40)	Z091.102.R ball bearing nut	RH/LH
T118.974.R	HSK-50 F	78	60	50	∅ 2÷26 (Art. T124/EOC25)	Z091.203.R	RH

COLLET CHUCKS HSK-63F

ART. T118

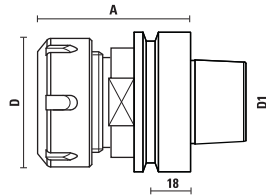

- The hollow taper shank is produced according to DIN69893
- Supplied with nut (without collet)
- Threaded nut and wrenches see page 7.33, spring collets see page 7.27, 7.28, 7.29
- Threaded nut DIN 6499
- Threaded nut DIN 6388 (EOC25)
- The "A" measure will be determined with clamped tool shanks by using our spring collet DIN6499 - DIN 6388/EOC25. The "A" measure may be subject to variations depending on the diameter of the clamped tools



Item	Taper	A	D	D1	Spring collets	Clamping nut	Rot.
T118.975.R	HSK-63 F	70	42	63	∅ 1÷16 (Art. T125/ER25)	Z091.103.R	RH
T118.976.R	HSK-63 F	75	50	63	∅ 2÷20 (Art. T119/ER32)	Z091.001.R	RH
T118.976.L	HSK-63 F	75	50	63	∅ 2÷20 (Art. T119/ER32)	Z091.001.L	LH
T118.978.R	HSK-63 F	76	50	63	∅ 2÷20 (Art. T119/ER32)	Z091.101.R ball bearing nut	RH/LH
T118.980.R	HSK-63 F	75	63	63	∅ 2÷30 (Art. T123/ER40)	Z091.002.R	RH
T118.980.L	HSK-63 F	75	63	63	∅ 2÷30 (Art. T123/ER40)	Z091.002.L	LH
T118.982.R	HSK-63 F	78	63	63	∅ 2÷30 (Art. T123/ER40)	Z091.102.R ball bearing nut	RH/LH
T118.983.R	HSK-63 F	78	60	63	∅ 2÷26 (Art. T124/EOC25)	Z091.202.R	RH
T118.984.R	HSK-63 F	78	60	63	∅ 2÷26 (Art. T124/EOC25)	Z091.203.R ball bearing nut	RH/LH
T118.994.R	HSK-63 F	115	60	63	∅ 2÷26 (Art. T124/EOC25)	Z091.203.R ball bearing nut	RH/LH

COLLET CHUCKS HSK-25E

ART. T118

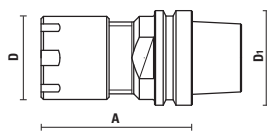

RPM
40.000

BALLUFF
POCKET

- The hollow taper shank is produced according to DIN69893
- Supplied with nut (without collet)
- Threaded nut and wrenches see page 7.33, spring collets see page 7.29
- Threaded nut DIN 6499
- Balanced to 40.000 RPM at G2,5 for "Multicam" machines
- The "A" measure will be determined with clamped tool shanks by using our spring collet DIN6499. The "A" measure may be subject to variations depending on the diameter of the clamped tools

Item	Taper	A	D	D1	Spring collets	Clamping nut	Rot.
T118.990.R	HSK-25E	40	22	25	Ø 1÷10 (Art. T127/ER16)	Z091.405.R Mini	RH

COLLET CHUCKS HSK-32E

ART. T118

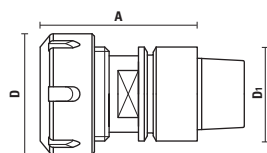

RPM
40.000

T139.132.N

BALLUFF
POCKET

- The hollow taper shank is produced according to DIN69893
- Supplied with nut (without collet)
- Threaded nut and wrenches see page 7.33, spring collets see page 7.28
- Threaded nut DIN 6499
- Balanced to 40.000 RPM at G2,5 for "Multicam" machines
- The "A" measure will be determined with clamped tool shanks by using our spring collet DIN6499. The "A" measure may be subject to variations depending on the diameter of the clamped tools

Item	Taper	A	D	D1	Spring collets	Clamping nut	Rot.
T118.991.R	HSK-32E	60	35	32	Ø 2÷13 (Art. T126/ER20)	Z091.104.R	RH
T118.992.R	HSK-32E	60	42	32	Ø 1÷16 (Art. T125/ER25)	Z091.103.R	RH

COLLET CHUCKS HSK-40E

ART. T118

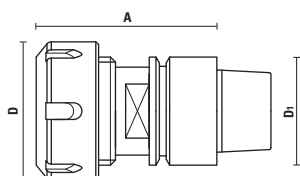

RPM
25.000

RPM
34.000

T139.140.N

BALLUFF
POCKET

- The hollow taper shank is produced according to DIN69893
- Supplied with nut (without collet)
- Threaded nut and wrenches see page 7.33, spring collets see page 7.26, 7.28
- Item T118.993.R balanced to 34.000 RPM at G2,5
- Item T118.995.R balanced to 25.000 RPM at G2,5
- The "A" measure will be determined with clamped tool shanks by using our spring collet DIN 6388 (EOC25). The "A" measure may be subject to variations depending on the diameter of the clamped tools

For "SD" machine

Item	Taper	A	D	D1	Spring collets	Clamping nut	Rot.
T118.993.R	HSK-40E	70	35	40	Ø 1÷16 (Art. T125/ER25)	Z091.403.R Mini	RH
T118.995.R	HSK-40E	70	50	40	Ø 2÷20 (Art. T119/ER32)	Z091.001.R	RH

COLLET CHUCKS HSK-50E

ART. T118

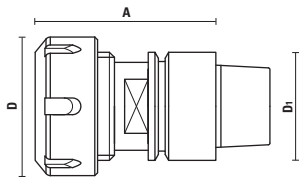

RPM
24.000

T139.150.N

BALLUFF
POCKET

- The hollow taper shank is produced according to DIN69893
- Supplied with nut (without collet)
- Threaded nut and wrenches see page 7.33, spring collets see page 7.26, 7.28
- The "A" measure will be determined with clamped tool shanks by using our spring collet DIN 6388 (EOC25). The "A" measure may be subject to variations depending on the diameter of the clamped tools

Item	Taper	A	D	D1	Spring collets	Clamping nut	Rot.
T118.997.R	HSK-50E	80	42	50	∅ 1÷16 (Art. T125/ER25)	Z091.103.R	RH
T118.998.R	HSK-50E	100	50	50	∅ 2÷20 (Art. T119/ER32)	Z091.001.R	RH

COLLET CHUCKS HSK-63E

ART. T118

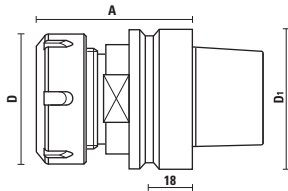

RPM
24.000

T139.163.N

BALLUFF
POCKET

- The hollow taper shank is produced according to DIN69893
- Supplied with nut (without collet)
- Threaded nut and wrenches see page 7.33, spring collets see page 7.26, 7.27, 7.30
- Threaded nut DIN 6499
- The "A" measure will be determined with clamped tool shanks by using our spring collet DIN6499. The "A" measure may be subject to variations depending on the diameter of the clamped tools

Item	Taper	A	D	D1	Spring collets	Clamping nut	Rot.
T118.985.R	HSK-63E	76	50	63	∅ 2÷20 (Art. T119/ER32)	Z091.001.R	RH
T118.985.N	HSK-63E	77	50	63	∅ 2÷20 (Art. T119/ER32)	Z091.101.R ball bearing nut	RH/LH
T118.985.R100	HSK-63E	100	50	63	∅ 2÷20 (Art. T119/ER32)	Z091.001.R	RH
T118.986.R	HSK-63E	76	50	63	∅ 2÷20 (Art. T134/ETS32)	Z091.301.R	RH
T118.987.R	HSK-63E	76	63	63	∅ 2÷30 (Art. T123/ER40)	Z091.002.R	RH
T118.987.N	HSK-63E	78	63	63	∅ 2÷30 (Art. T123/ER40)	Z091.102.R ball bearing nut	RH/LH
T118.988.R	HSK-63E	76	63	63	∅ 2÷25 (Art. T135/ETS40)	Z091.302.R	RH

COLLET CHUCKS HSK-50E WITH FLANGE ∅ 40

ART. T118

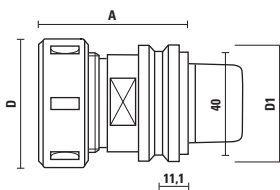

RPM
24.000

T139.150.N

BALLUFF
POCKET

- The hollow taper shank is produced according to DIN69893
- Supplied with nut (without collet)
- Threaded nut and wrenches see page 7.33, spring collets see page 7.27
- Threaded nut DIN 6388 (EOC25)
- The "A" measure will be determined with clamped tool shanks by using our spring collet DIN 6388 (EOC25). The "A" measure may be subject to variations depending on the diameter of the clamped tools

Item	Taper	A	D	D1	Spring collets	Clamping nut	Rot.
T118.996.R	HSK-50E	75	60	50	∅ 2÷26 (Art. T124/EOC25)	Z091.203.R ball bearing nut	RH/LH

- For ALBERTI "Polar"

LONGER COLLET CHUCKS HSK-63F FOR HIGH SPEED PRODUCTION WITH LOW NOISE KleinOVERLINE

The increasing use of 5-axis machines has enabled to step up the possible workings and with it the need to perform operations in tight and hard to reach spaces.

In order to meet these needs with the **utmost precision and excellent finishes** we offer a range of special HSK63F tool holders for collets **ER16, ER32** and **DIN6388/EOC25**, balanced at grade **G 2.5** at **36,000 RPM**.

Main features **KleinOVERLINE**

- Accessibility
- Balance
- Rotation speed
- Noiselessness
- Extended length tool holders, reaching 200 mm.
- G 2.5 balancing grade
- 36.000 RPM
- No-noise nuts, with ground contours

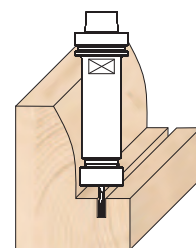

COLLET CHUCKS HSK-63F ER16 - G2.5 BALANCING

ART. TK118

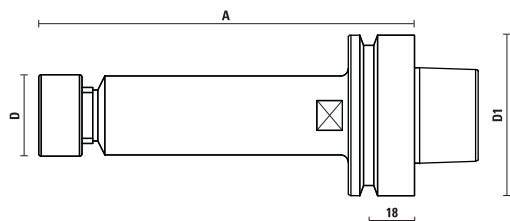

KleinOVERLINE

- The hollow taper shank is produced according to DIN69893
- **Balanced at grade G 2.5 to 36.000 RPM**
- **Noise and vibrations reduction thanks to the special nut without cuts**
- Supplied with nut (without collet)
- Threaded nut and wrenches see page 7.33, spring collets see page 7.29
- Threaded nut DIN 6499
- The "A" measure will be determined with clamped tool shanks by using our spring collet DIN6499. The "A" measure may be subject to variations depending on the diameter of the clamped tools.

RPM
36.000



BALLUFF
POCKET

Item	Taper	A	D	D1	Spring collets	Clamping nut	Rot.
TK118.900.R070	HSK-63F	70	32	63	∅ 1÷10 (Art. T127/ER16)	Z091.505.R	RH
TK118.900.R100	HSK-63F	100	32	63	∅ 1÷10 (Art. T127/ER16)	Z091.505.R	RH
TK118.900.R150	HSK-63F	150	32	63	∅ 1÷10 (Art. T127/ER16)	Z091.505.R	RH

COLLET CHUCKS HSK-63F ER32 - G2.5 BALANCING

ART. TK118

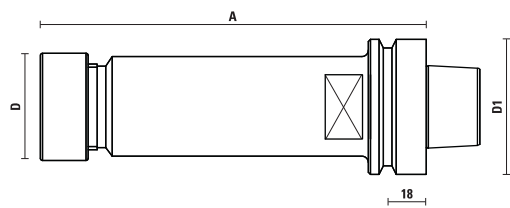

KleinOVERLINE

- The hollow taper shank is produced according to DIN69893
- **Balanced at grade G 2.5 to 36.000 RPM**
- **Noise and vibrations reduction thanks to the special nut without cuts**
- Supplied with nut (without collet)
- Threaded nut and wrenches see page 7.33, spring collets see page 7.26
- Threaded nut DIN 6499
- The "A" measure will be determined with clamped tool shanks by using our spring collet DIN6499. The "A" measure may be subject to variations depending on the diameter of the clamped tools.

RPM
36.000



BALLUFF
POCKET

Item	Taper	A	D	D1	Spring collets	Clamping nut	Rot.
TK118.976.R075	HSK-63F	75	50	63	∅ 2÷20 (Art. T119/ER32)	Z091.501.R	RH
TK118.976.R100	HSK-63F	100	50	63	∅ 2÷20 (Art. T119/ER32)	Z091.501.R	RH
TK118.976.R125	HSK-63F	125	50	63	∅ 2÷20 (Art. T119/ER32)	Z091.501.R	RH
TK118.976.R180	HSK-63F	180	50	63	∅ 2÷20 (Art. T119/ER32)	Z091.501.R	RH

COLLET CHUCKS HSK-63F DIN6388/EOC25 - G2.5 BALANCING

ART. TK118

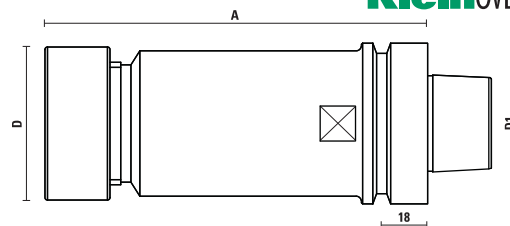

KleinOVERLINE

- The hollow taper shank is produced according to DIN69893
- **Balanced at grade G 2.5 to 36.000 RPM**
- **Noise and vibrations reduction thanks to the special nut without cuts**
- Supplied with nut (without collet)
- Threaded nut and wrenches see page 7.33, spring collets see page 7.27
- Threaded nut DIN 6499
- The "A" measure will be determined with clamped tool shanks by using our spring collet DIN6499. The "A" measure may be subject to variations depending on the diameter of the clamped tools.

RPM
36.000



BALLUFF
POCKET

Item	Taper	A	D	D1	Spring collets	Clamping nut	Rot.
TK118.984.R078	HSK-63F	78	60	63	∅ 2÷26 (Art. T124/EOC25)	Z091.522.R	RH
TK118.984.R115	HSK-63F	115	60	63	∅ 2÷26 (Art. T124/EOC25)	Z091.522.R	RH
TK118.984.R150	HSK-63F	150	60	63	∅ 2÷26 (Art. T124/EOC25)	Z091.522.R	RH
TK118.984.R200	HSK-63F	200	60	63	∅ 2÷26 (Art. T124/EOC25)	Z091.522.R	RH

COLLET CHUCKS HSK-63F ER16 - G2.5 BALANCING

ART. TJ118

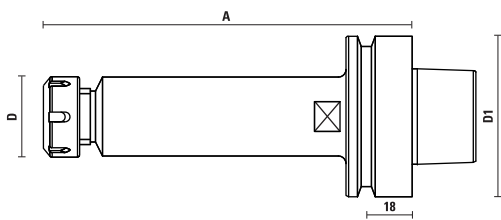

- The hollow taper shank is produced according to DIN69893
- **Balanced at G2.5**
- Maximum speed rotation at **36.000 RPM**
- Supplied with standard clamping nut
- Threaded nut and wrenches (see page 7.33)
- The "A" measure will be determined with clamped tool shanks by using our spring collet DIN6499.
- The "A" measure may be subject to variations depending on the diameter of the clamped tools.

RPM
36.000



BALLUFF
POCKET

Item	Taper	A	D	D1	Spring collets	Clamping nut	Rot.
TJ118.900.R070	HSK-63F	70	32	63	∅ 1÷10 (Art. T127/ER16)	Z091.105.R	RH
TJ118.900.R100	HSK-63F	100	32	63	∅ 1÷10 (Art. T127/ER16)	Z091.105.R	RH
TJ118.900.R150	HSK-63F	150	32	63	∅ 1÷10 (Art. T127/ER16)	Z091.105.R	RH

COLLET CHUCKS HSK-63F ER32 - G2.5 BALANCING

ART. TJ118

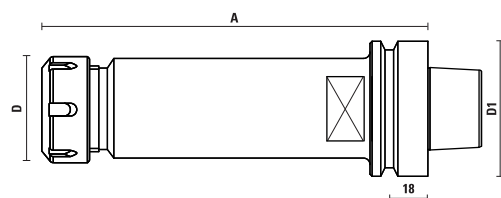

- The hollow taper shank is produced according to DIN69893
- **Balanced at G2.5**
- Maximum speed rotation at **36.000 RPM**
- Supplied with standard clamping nut
- Threaded nut and wrenches (see page 7.33)
- The "A" measure will be determined with clamped tool shanks by using our spring collet DIN6499.
- The "A" measure may be subject to variations depending on the diameter of the clamped tools.

RPM
36.000



BALLUFF
POCKET

Item	Taper	A	D	D1	Spring collets	Clamping nut	Rot.
TJ118.976.R075	HSK-63F	75	50	63	∅ 2÷20 (Art. T119/ER32)	Z091.001.R	RH
TJ118.976.R100	HSK-63F	100	50	63	∅ 2÷10 (Art. T119/ER32)	Z091.001.R	RH
TJ118.976.R125	HSK-63F	125	50	63	∅ 2÷20 (Art. T119/ER32)	Z091.001.R	RH
TJ118.976.R180	HSK-63F	180	50	63	∅ 2÷20 (Art. T119/ER32)	Z091.001.R	RH

COLLET CHUCKS HSK-63F DIN6388/EOC25 - G2.5 BALANCING

ART. TJ118

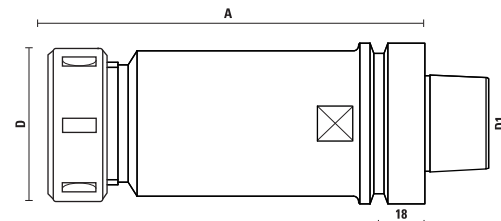

- The hollow taper shank is produced according to DIN69893
- **Balanced at G2.5**
- Maximum speed rotation at **36.000 RPM**
- Supplied with standard clamping nut
- Threaded nut and wrenches (see page 7.33)
- The "A" measure will be determined with clamped tool shanks by using our spring collet DIN6499.
- The "A" measure may be subject to variations depending on the diameter of the clamped tools.

RPM
36.000



BALLUFF
POCKET

Item	Taper	A	D	D1	Spring collets	Clamping nut	Rot.
TJ118.984.R078	HSK-63F	78	60	63	∅ 2÷26 (Art. T124/EOC25)	Z091.202.R	RH
TJ118.984.R115	HSK-63F	115	60	63	∅ 2÷26 (Art. T124/EOC25)	Z091.202.R	RH
TJ118.984.R150	HSK-63F	150	60	63	∅ 2÷26 (Art. T124/EOC25)	Z091.202.R	RH
TJ118.984.R200	HSK-63F	200	60	63	∅ 2÷26 (Art. T124/EOC25)	Z091.202.R	RH

COLLET CHUCKS DIN 6499 (ER32) FOR BACCI AND GREDA

ART. T118

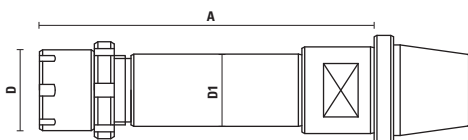

- Supplied with ER20 Mini nut and return ring nut (without spring collet)

- The "A" measure will be determined with clamped tool shanks by using our spring collet DIN 6499. The "A" measure may be subject to variations depending on the diameter of the clamped tools

RPM
24.000

For: Bacci/Greda

Item	A	D	D1	Spring collets	Clamping nut	Return ring nut	Rot.
T118.935.R	85	28	25	∅ 2÷13 (Art. T126/ER20)	Z091.404.R (ER20 Mini)	Z091.904.R	RH

COLLET CHUCKS HSK-85 FOR WEINIG

ART. T132

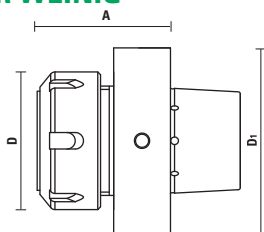

- The hollow taper shank is produced according to DIN69893

- Supplied with nut (without collet)

- Threaded nut DIN 6499

- The "A" measure will be determined with clamped tool shanks by using our spring collet DIN6499. The "A" measure may be subject to variations depending on the diameter of the clamped tools

RPM
24.000



BALLUFF
POCKET

For Weinig machine

Item	Taper	A	D	D1	Spring collets	Clamping nut	Rot.
T132.982.R	HSK-85	61	63	85	∅ 2÷30 (Art. T123/ER40)	Z091.102.R with ball bearing nut	Rh-Lh

STRAIGHT SHANK TOOL EXTENSION

ART. T121



- To be used on ER tool holders

- Suitable for working deep and hard to reach surfaces

Item	D	Spring collets	Clamping nut	S	L	L1	Rot.
T121.016.120.080	22	∅ 2÷10 (Art. T127/ER16)	Z091.405.R Mini	12	80	118	RH
T121.016.160.100	22	∅ 2÷10 (Art. T127/ER16)	Z091.405.R Mini	16	100	138	RH
T121.016.200.100	22	∅ 2÷10 (Art. T127/ER16)	Z091.405.R Mini	20	100	131	RH
T121.016.200.160	22	∅ 2÷10 (Art. T127/ER16)	Z091.405.R Mini	20	160	191	RH
T121.016.200.200	22	∅ 2÷10 (Art. T127/ER16)	Z091.405.R Mini	20	200	231	RH
T121.020.160.100	28	∅ 2÷13 (Art. T126/ER20)	Z091.404.R Mini	16	100	142	RH
T121.020.160.160	28	∅ 2÷13 (Art. T126/ER20)	Z091.404.R Mini	16	160	202	RH
T121.020.200.100	28	∅ 2÷13 (Art. T126/ER20)	Z091.404.R Mini	20	100	137	RH
T121.020.200.160	28	∅ 2÷13 (Art. T126/ER20)	Z091.404.R Mini	20	160	197	RH
T121.020.250.160	28	∅ 2÷13 (Art. T126/ER20)	Z091.404.R Mini	25	160	188	RH
T121.020.250.240	28	∅ 2÷13 (Art. T126/ER20)	Z091.404.R Mini	25	240	282	RH
T121.025.200.060	35	∅ 3÷16 (Art. T125/ER25)	Z091.403.R Mini	20	60	106	RH
T121.025.200.100	35	∅ 3÷16 (Art. T125/ER25)	Z091.403.R Mini	20	100	146	RH
T121.025.200.160	35	∅ 3÷16 (Art. T125/ER25)	Z091.403.R Mini	20	160	206	RH
T121.025.250.100	42	∅ 3÷16 (Art. T125/ER25)	Z091.103.R	25	100	140	RH
T121.025.250.160	42	∅ 3÷16 (Art. T125/ER25)	Z091.103.R	25	160	200	RH

Example of use:

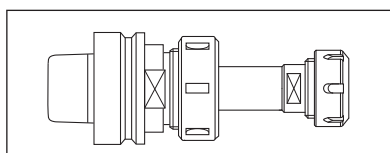

- For a proper use and maximum holding power, fill the collet all the way with the extension shank;

- It is very important to tighten the collet nut of tool holder to recommended torque using a torque wrench;

- When the extension is mounted, balancing grade is not guaranteed.

STAINLESS STEEL COLLET CHUCKS

- Solid stainless steel collet chucks are more resistant and have a longer life span;
- A special treatment guarantees an excellent resistance to corrosion and an aesthetic pleasing;
- No problems of peeling compared to coated chrome chucks of our competitors;
- Better working performances and longer life of the electrospindles;

- Produced in stainless steel AISI 420;
- Needed when working with coolant: machines for marble, glass, aluminium working and others;
- Highly recommended when processing resinoid wood and composite materials;
- Suggested when working in "humid" environment;
- Extremely low maintenance costs, easy to clean.



COLLET CHUCKS ISO 30 INOX

ART. T118

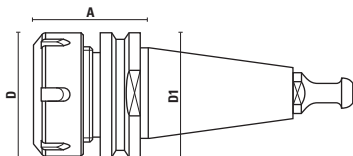

- The hollow taper shank is produced according to DIN69893
- The "A" measure will be determined with clamped tool shanks by using our spring collet DIN6499. The "A" measure may be subject to variations depending on the diameter of the clamped tools.

RPM
24.000



BALLUFF
POCKET

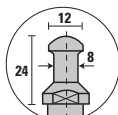

Item T118.891.R For:
Biesse (after 09/09/92),
Masterwood - Bulleri (motor H.S.D.), **Vitap, Hiteco**

Item	Taper	A	D	D1	Spring collets	Clamping nut	Rot.
T118.800.RAI	ISO 30	50	50	50	∅ 2÷20 (Art. T119/ER32)	Z091.001.R	RH
T118.802.RAI	ISO 30	50	50	50	∅ 2÷20 (Art. T119/ER32)	Z091.101.R ball bearing nut	RH/LH
T118.830.RAI	ISO 30	55	63	50	∅ 2÷30 (Art. T123/ER40)	Z091.002.R	RH
T118.832.RAI	ISO 30	55	63	50	∅ 2÷30 (Art. T123/ER40)	Z091.102.R ball bearing nut	RH/LH

RPM
24.000



BALLUFF
POCKET

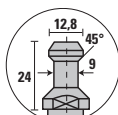

Item T118.792.R For:
Alberti, Vitap, Masterwood (motor G. Colombo)

Item	Taper	A	D	D1	Spring collets	Clamping nut	Rot.
T118.811.RAI	ISO 30	50	50	50	∅ 2÷20 (Art. T119/ER32)	Z091.001.R	RH
T118.813.RAI	ISO 30	50	50	50	∅ 2÷20 (Art. T119/ER32)	Z091.101.R ball bearing nut	RH/LH
T118.815.RAI	ISO 30	55	63	50	∅ 2÷30 (Art. T123/ER40)	Z091.002.R	RH
T118.817.RAI	ISO 30	55	63	50	∅ 2÷30 (Art. T123/ER40)	Z091.102.R ball bearing nut	RH/LH

RPM
24.000



BALLUFF
POCKET

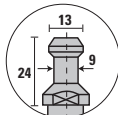

Item T118.791.R (DIN 69872) For:
Anderson, Busellato, Weeke, Ima, Bulleri, Maka, Cosmec, Reichenbacher, Elte

Item	Taper	A	D	D1	Spring collets	Clamping nut	Rot.
T118.821.RAI	ISO 30	50	50	50	∅ 2÷20 (Art. T119/ER32)	Z091.001.R	RH
T118.823.RAI	ISO 30	50	50	50	∅ 2÷20 (Art. T119/ER32)	Z091.101.R ball bearing nut	RH/LH
T118.825.RAI	ISO 30	55	63	50	∅ 2÷30 (Art. T123/ER40)	Z091.002.R	RH
T118.827.RAI	ISO 30	55	63	50	∅ 2÷30 (Art. T123/ER40)	Z091.102.R ball bearing nut	RH/LH

COLLET CHUCKS HSK-63F INOX

ART. T118

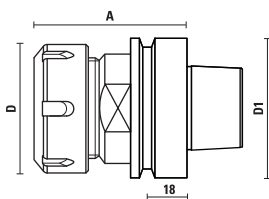

- The hollow taper shank is produced according to DIN69893
- The "A" measure will be determined with clamped tool shanks by using our spring collet DIN6499. The "A" measure may be subject to variations depending on the diameter of the clamped tools.

RPM
24.000



BALLUFF
POCKET

Item	Taper	A	D	D1	Spring collets	Clamping nut	Rot.
T118.976.RAI	HSK-63F	74	50	63	∅ 2÷20 (Art. T119/ER32)	Z091.001.R	RH
T118.978.RAI	HSK-63F	74	50	63	∅ 2÷20 (Art. T119/ER32)	Z091.101.R ball bearing nut	RH/LH
T118.980.RAI	HSK-63F	77	63	63	∅ 2÷30 (Art. T123/ER40)	Z091.002.R	RH
T118.982.RAI	HSK-63F	77	63	63	∅ 2÷30 (Art. T123/ER40)	Z091.102.R ball bearing nut	RH/LH
T118.983.RAI	HSK-63F	78	60	63	∅ 2÷26 (Art. T124/EOC25)	Z091.202.R	RH
T118.984.RAI	HSK-63F	78	60	63	∅ 2÷26 (Art. T124/EOC25)	Z091.203.R ball bearing nut	RH/LH

COLLET CHUCKS ISO 30 FOR MULTIAX

ART. T118

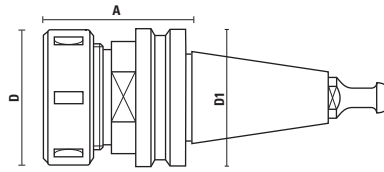

RPM
24.000

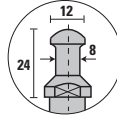

- Supplied with nut (without collet) and retaining pawl
- The "A" measure will be determined with clamped tool shanks by using our spring collet
The "A" measure may be subject to variations depending on the diameter of the clamped tools
- To be used with our spring collets with 3° taper angle only (see item T133 at page 7.30)
- **Special micro-shot peening treatment**

Item T118.891.R for:
Biesse, Masterwood, Multiax, Vitap, Hiteco

Item	Taper	A	D	D1	Spring collets	Clamping nut	Rot.
T118.841.R	ISO 30	58	50	50	∅ 3÷25,4	Z091.005.R	RH

COLLET CHUCKS HSK-63F FOR MULTIAX

ART. T118

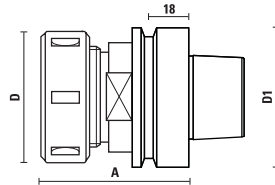

RPM
24.000



- Supplied with nut (without collet) and retaining pawl
- The "A" measure will be determined with clamped tool shanks by using our spring collet
The "A" measure may be subject to variations depending on the diameter of the clamped tools
- To be used with our spring collets with 3° taper angle only (see item T133 at page 7.30)
- **Special micro-shot peening treatment**

For: **Multiax**

Item	Taper	A	D	D1	Spring collets	Clamping nut	Rot.
T118.941.R	HSK 63F	58	50	63	∅ 3÷25,4	Z091.005.R	RH
T118.941.L	HSK-63F	58	50	63	∅ 3÷25,4	Z091.005.R	LH

SPRING COLLETS

Our **HIGH-PRECISION spring collets** are produced in Italy and have 0,01 mm precision (0.0004" TIR) with perfect precision and reliability, ensuring longer tool life of the spindle and better working operations. They are fully grounded both externally and internally; after this operation there is a second phase of finishing which aims to eliminate all ridges and burrs from machining by obtaining a surface "superfinish" by ensuring a grade of roughness lower than Rz 2,5. They are completely quenched and tempered (HRC 45+2). Our line of **ULTRA-PRECISE spring collets** are produced to give to the tool holders and spindle the maximum efficiency based on the balancing grade. They are made in special spring steel with a concentricity specification of 0,005 mm (0.0002" TIR).

HOW TO INSERT THE SPRING COLLET IN THE NUT

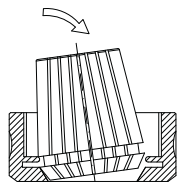

Right procedure to assemble the collet in the nut:

- place the collet diagonal to the clamping nut and lock it from the side by pressing it from top
- screw the nut and be sure the shank is correctly inserted in the spring collet.

Tighten the nut using the apposite key on the proper demount device (Art. T139, see page 7.41)

Do not place the spring collet in the collet chuck before you have it properly inserted in the nut.

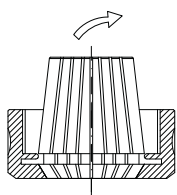

Correct procedure for tool and spring collet change:

- place the collet chuck in the mounting device
- untighten the clamping nut
- open the clamping nut and pull the cutting tool out holding it on the shank
- release the collet from the clamping nut by lateral pressure

CONCENTRICITY

Using high precision spring collets, vibrations on the tools and motors are reduced, assuring better results and a longer life of the tools and electro-spindles.

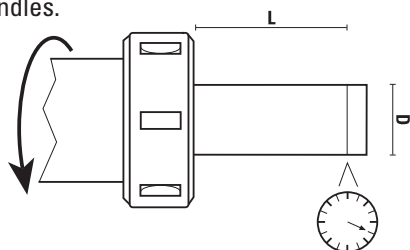

D	L	Standard High Precision	Ultra Precision
		HP >0,010	UP >0,005
Ø3 - Ø4 - Ø5	16	> 0,010	> 0,005
Ø6 ÷ Ø9,5	25	> 0,010	> 0,005
Ø10 ÷ Ø17	40	> 0,010	> 0,005
Ø18 ÷ Ø26	50	> 0,010	> 0,005

TECHNICAL INFORMATION

Type	ER11 4008 E - DIN 6499	ER16 426 E - DIN 6499	ER20 428 E - DIN 6499	ER25 430 E - DIN 6499	ER32 470 E - DIN 6499	ER40 472 E - DIN 6499	EOC12 SYOZ20-407 E DIN 6388	EOC16 RD025-415 E DIN 6388	EOC25 SYOZ25-462E DIN 6388
Diameter range	1÷7	1÷10	2÷13	1÷16	2÷20	2÷30	4÷12,7	4÷12,7	2÷25,4
Clamping range	0,5	0,5÷1	0,5÷1	0,5÷1	0,5÷1	0,5÷1	0,5	0,5	0,5

COLLET LIFE SPAN

Spring collets have a life span of approximately 3 months if used 8 hours a day. Replacing the collets will ensure your operation runs consistency and prevents from tool breakag.

MAINTENANCE

Keeping spring collets and tools clean is essential for a longer life. The worked material produces chips and dirt which can cause an elliptical tool rotation. The seats of collet chucks and electrospindles should be cleaned daily with the correct tapers (see our items T137 and X137 at the page 7.40).



DID YOU KNOW?

Collets are manufactured from spring steel and regular usage causes a loss of elasticity. Therefore, collets need to be replaced regularly as part of on-going maintenance while the average collet should be replaced every 500-600 hours of run time. Avoiding regular replacement can lead to brittle collets, which may crack or break, and cause permanent damage to the spindle. Replacement of collets is more economical than replacing router bits or expensive spindles. Rigidity and concentricity are the key elements in any routing application. Periodically, tool holders should be examined for wear and if necessary replaced to maintain great cutting performance. The simple process of colletting router tools, maintaining collets, and regularly replacing them - safeguards productivity and ensures a perfect finish.



SPRING COLLETS ER 32 - DIN 6499

ART. T119

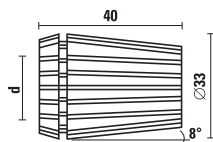

HP
>0,010

Item	d
T119.020.N	Ø 2 - 1
T119.030.N	Ø 3 - 2
T119.032.N	Ø 3,2 (1/8")
T119.040.N	Ø 4 - 3
T119.048.N	Ø 4,8 (3/16")
T119.050.N	Ø 5 - 4
T119.060.N	Ø 6 - 5
T119.064.N	Ø 6,4 (1/4")
T119.070.N	Ø 7 - 6
T119.079.N	Ø 7,9 (5/16")
T119.080.N	Ø 8 - 7
T119.090.N	Ø 9 - 8
T119.095.N	Ø 9,5 (3/8")
T119.100.N	Ø 10 - 9
T119.110.N	Ø 11 - 10
T119.120.N	Ø 12 - 11
T119.127.N	Ø 12,7 (1/2")
T119.130.N	Ø 13 - 12
T119.140.N	Ø 14 - 13
T119.150.N	Ø 15 - 14
T119.159.N	Ø 15,9 (5/8")
T119.160.N	Ø 16 - 15
T119.170.N	Ø 17 - 16
T119.180.N	Ø 18 - 17
T119.190.N	Ø 19 - 18
T119.191.N	Ø 19,1 (3/4")
T119.200.N	Ø 20 - 19

SPRING COLLET SET ER 32 - DIN 6499

ART. X119



- Complete with 18 pcs
- In plastic Box

HP
>0,010

Item	Diameters:
X119.118.N	Ø3 - Ø4 - Ø5 - Ø6 - Ø7 - Ø8
	Ø9 - Ø10 - Ø11 - Ø12 - Ø13 - Ø14
	Ø15 - Ø16 - Ø17 - Ø18 - Ø19 - Ø20

ULTRA PRECISION SPRING COLLETS ER 32 - DIN 6499

ART. T119.UP

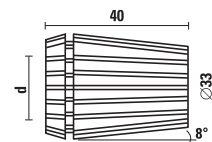

UP
>0,005

- Recommended for high speed RPM where great machining precision is required
- Nominal diameter
- To be used on all types of toolholders and standard nuts

Item	d
T119.030.NUP	Ø 3
T119.040.NUP	Ø 4
T119.060.NUP	Ø 6
T119.080.NUP	Ø 8
T119.100.NUP	Ø 10
T119.120.NUP	Ø 12
T119.140.NUP	Ø 14
T119.160.NUP	Ø 16
T119.180.NUP	Ø 18
T119.200.NUP	Ø 20

SPRING COLLETS ER 40 - DIN 6499

ART. T123

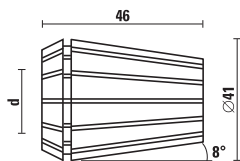

HP
>0,010

Item	d
T123.030.N	Ø 3 - 2
T123.032.N	Ø 3,2 (1/8")
T123.040.N	Ø 4 - 3
T123.048.N	Ø 4,8 (3/16")
T123.050.N	Ø 5 - 4
T123.060.N	Ø 6 - 5
T123.064.N	Ø 6,4 (1/4")
T123.070.N	Ø 7 - 6
T123.079.N	Ø 7,9 (5/16")
T123.080.N	Ø 8 - 7
T123.090.N	Ø 9 - 8
T123.095.N	Ø 9,5 (3/8")
T123.100.N	Ø 10 - 9
T123.110.N	Ø 11 - 10
T123.120.N	Ø 12 - 11
T123.127.N	Ø 12,7 (1/2")
T123.130.N	Ø 13 - 12
T123.140.N	Ø 14 - 13
T123.150.N	Ø 15 - 14
T123.159.N	Ø 15,9 (5/8")
T123.160.N	Ø 16 - 15
T123.170.N	Ø 17 - 16
T123.180.N	Ø 18 - 17
T123.190.N	Ø 19 - 18
T123.191.N	Ø 19,1 (3/4")
T123.200.N	Ø 20 - 19
T123.210.N	Ø 21 - 20
T123.220.N	Ø 22 - 21
T123.230.N	Ø 23 - 22
T123.240.N	Ø 24 - 23
T123.250.N	Ø 25 - 24
T123.254.N	Ø 25,4 (1")
T123.260.N	Ø 26 - 25
T123.300.N	Ø 30 - 29

SPRING COLLET SET ER 40 - DIN 6499

ART. X123



- Complete with 23 pcs
- In carton Box

HP
>0,010

Item	Diameters:
X123.023.N	Ø3 - Ø4 - Ø5 - Ø6 - Ø7 - Ø8
	Ø9 - Ø10 - Ø11 - Ø12 - Ø13 - Ø14
	Ø15 - Ø16 - Ø17 - Ø18 - Ø19 - Ø20
	Ø21 - Ø22 - Ø23 - Ø24 - Ø25

ULTRA PRECISION SPRING COLLETS ER 40 - DIN 6499

ART. T123.UP

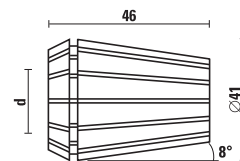

- Recommended for high speed RPM where great machining precision is required
- Nominal diameter
- To be used on all types of toolholders and standard nuts

UP
>0,005

Item	d
T123.060.NUP	Ø 6
T123.080.NUP	Ø 8
T123.100.NUP	Ø 10
T123.120.NUP	Ø 12
T123.140.NUP	Ø 14
T123.160.NUP	Ø 16
T123.180.NUP	Ø 18
T123.200.NUP	Ø 20
T123.250.NUP	Ø 25

SPRING COLLETS EOC25 - DIN 6388 (462 E)

ART. T124

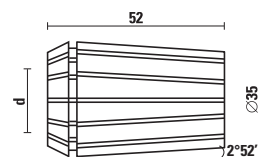

HP
>0,008

Item	d
T124.020.N	Ø 2 - 1,5
T124.030.N	Ø 3 - 2,5
T124.032.N	Ø 3,2 (1/8")
T124.040.N	Ø 4 - 3,5
T124.048.N	Ø 4,8 (3/16")
T124.050.N	Ø 5 - 4,5
T124.060.N	Ø 6 - 5,5
T124.064.N	Ø 6,4 (1/4")
T124.070.N	Ø 7 - 6,5
T124.079.N	Ø 7,9 (5/16")
T124.080.N	Ø 8 - 7,5
T124.095.N	Ø 9,5 (3/8")
T124.100.N	Ø 10 - 9,5
T124.110.N	Ø 11 - 10,5
T124.120.N	Ø 12 - 11,5
T124.127.N	Ø 12,7 (1/2")
T124.130.N	Ø 13 - 12,5
T124.140.N	Ø 14 - 13,5
T124.159.N	Ø 15,9 (5/8")
T124.160.N	Ø 16 - 15,5
T124.180.N	Ø 18 - 17,5
T124.190.N	Ø 19 - 18,5
T124.191.N	Ø 19,1 (3/4")
T124.200.N	Ø 20 - 19,5
T124.220.N	Ø 22 - 21,5
T124.250.N	Ø 25 - 24,5
T124.254.N	Ø 25,4 (1")

SPRING COLLETS ER 25 - DIN 6499

ART. T125

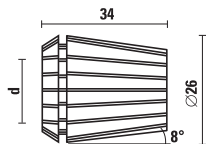

HP
>0,010

Item	d
T125.016.N	Ø 1,59 (1/16")
T125.020.N	Ø 2 - 1
T125.030.N	Ø 3 - 2
T125.032.N	Ø 3,2 (1/8")
T125.040.N	Ø 4 - 3
T125.048.N	Ø 4,8 (3/16")
T125.050.N	Ø 5 - 4
T125.060.N	Ø 6 - 5
T125.064.N	Ø 6,4 (1/4")
T125.070.N	Ø 7 - 6
T125.079.N	Ø 7,9 (5/16")
T125.080.N	Ø 8 - 7
T125.090.N	Ø 9 - 8
T125.095.N	Ø 9,5 (3/8")
T125.100.N	Ø 10 - 9
T125.110.N	Ø 11 - 10
T125.120.N	Ø 12 - 11
T125.127.N	Ø 12,7 (1/2")
T125.130.N	Ø 13 - 12
T125.140.N	Ø 14 - 13
T125.150.N	Ø 15 - 14
T125.159.N	Ø 15,9 (5/8")
T125.160.N	Ø 16 - 15

ULTRA PRECISION SPRING COLLETS ER 25 - DIN 6499

ART. T125.UP

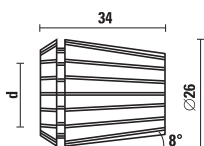

UP
>0,005

- Recommended for high speed RPM where great machining precision is required
- Nominal diameter
- To be used on all types of toolholders and standard nuts

Item	d
T125.060.NUP	Ø 6
T125.080.NUP	Ø 8
T125.100.NUP	Ø 10
T125.120.NUP	Ø 12

SPRING COLLET SET ER25 - DIN 6499

ART. X125



- Complete with 14 pcs
- In wooden Box

Item	Diameters: Ø3 - Ø4 - Ø5 - Ø6 - Ø7 - Ø8 - Ø9 - Ø10 - Ø11 - Ø12 - Ø13 - Ø14 - Ø15 - Ø16
X125.014.N	

SPRING COLLETS ER 20 - DIN 6499

ART. T126

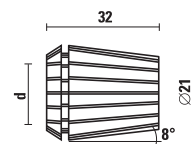

HP
>0,010

Item	d
T126.016.N	Ø 1,59 (1/16")
T126.030.N	Ø 3 - 2
T126.032.N	Ø 3,2 (1/8")
T126.040.N	Ø 4 - 3
T126.048.N	Ø 4,8 (3/16")
T126.050.N	Ø 5 - 4
T126.060.N	Ø 6 - 5
T126.064.N	Ø 6,4 (1/4")
T126.070.N	Ø 7 - 6
T126.080.N	Ø 8 - 7
T126.090.N	Ø 9 - 8
T126.095.N	Ø 9,5 (3/8")
T126.100.N	Ø 10 - 9
T126.110.N	Ø 11 - 10
T126.120.N	Ø 12 - 11
T126.127.N	Ø 12,7 (1/2")
T126.130.N	Ø 13 - 12

ULTRA PRECISION SPRING COLLETS ER 20 - DIN 6499

ART. T126.UP

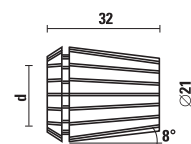

UP
>0,005

- Recommended for high speed RPM where great machining precision is required
- Nominal diameter
- To be used on all types of toolholders and standard nuts

Item	d
T126.060.NUP	Ø 6
T126.080.NUP	Ø 8
T126.100.NUP	Ø 10
T126.120.NUP	Ø 12

SPRING COLLETS ER 16 - DIN 6499

ART. T127

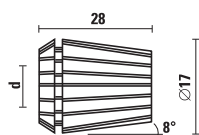

HP
>0,010

Item	d
T127.016.N	Ø 1,59 (1/16")
T127.020.N	Ø 2 - 1
T127.030.N	Ø 3 - 2
T127.032.N	Ø 3,2 (1/8")
T127.040.N	Ø 4 - 3
T127.050.N	Ø 5 - 4
T127.060.N	Ø 6 - 5
T127.064.N	Ø 6,4 (1/4")
T127.070.N	Ø 7 - 6
T127.080.N	Ø 8 - 7
T127.090.N	Ø 9 - 8
T127.095.N	Ø 9,5 (3/8")
T127.100.N	Ø 10 - 9

ULTRA PRECISION SPRING COLLETS ER 16 - DIN 6499

ART. T127.UP

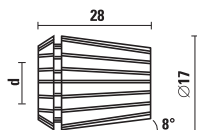

- Recommended for high speed RPM where great machining precision is required
- Nominal diameter
- To be used on all types of toolholders and standard nuts

UP
>0,005

Item	d
T127.060.NUP	Ø 6
T127.080.NUP	Ø 8
T127.100.NUP	Ø 10

SPRING COLLETS ER 11 - DIN 6499

ART. T129

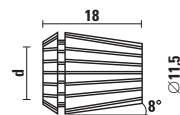

HP
>0,010

Item	d
T129.010.N	Ø 1-0,5
T129.015.N	Ø 1,5-1
T129.020.N	Ø 2-1,5
T129.025.N	Ø 2,5-2
T129.030.N	Ø 3-2,5
T129.032.N	Ø 3,2 (1/8")
T129.035.N	Ø 3,5-3
T129.040.N	Ø 4-3,5
T129.045.N	Ø 4,5-4
T129.048.N	Ø 4,8 (3/16")
T129.050.N	Ø 5-4,5
T129.055.N	Ø 5,5-5
T129.060.N	Ø 6-5,5
T129.064.N	Ø 6,4 (1/4")
T129.065.N	Ø 6,5-6
T129.070.N	Ø 7-6,5

SPRING COLLETS EOC12 - DIN 6388 (407E)

ART. T136

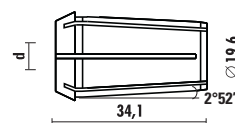

HP
>0,010

- To be used with Art. T118.580.R

Item	d
T136.040.N	Ø 4 - 3
T136.060.N	Ø 6 - 5
T136.064.N	Ø 6,4 (1/4")
T136.080.N	Ø 8 - 7
T136.095.N	Ø 9,5 (3/8")
T136.100.N	Ø 10 - 9
T136.120.N	Ø 12 - 11
T136.127.N	Ø 12,7 (1/2")

SPRING COLLETS EOC16 - DIN 6388 (415E)

ART. T138

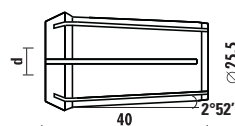

HP
>0,010

Item	d
T138.040.N	Ø 4 - 3
T138.060.N	Ø 6 - 5
T138.064.N	Ø 6,4 (1/4")
T138.080.N	Ø 8 - 7
T138.095.N	Ø 9,5 (3/8")
T138.100.N	Ø 10 - 9
T138.120.N	Ø 12 - 11
T138.127.N	Ø 12,7 (1/2")

SPRING COLLETS 3° TAPER ANGLE FOR MULTIAX

ART. T133

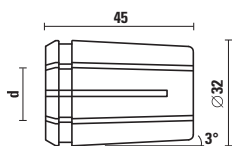

To be used with our tool holders (see item T118.941.R and T118.841.R) for Multiax router machines only.

HP
>0,010

Item	d	Item	d
T133.032.N	Ø 3,2 (1/8")	T133.120.N	Ø 12 - 11
T133.040.N	Ø 4 - 3	T133.127.N	Ø 12,7 (1/2")
T133.060.N	Ø 6 - 5	T133.159.N	Ø 15,9 (5/8")
T133.064.N	Ø 6,4 (1/4")	T133.160.N	Ø 16 - 15
T133.079.N	Ø 7,9 (5/16")	T133.191.N	Ø 19,1 (3/4")
T133.080.N	Ø 8 - 7	T133.200.N	Ø 20 - 19
T133.095.N	Ø 9,5 (3/8")	T133.250.N	Ø 25 - 24
T133.100.N	Ø 10 - 9	T133.254.N	Ø 25,4 (1")

SPRING COLLETS ETS 32 - DIN 6499

ART. T134

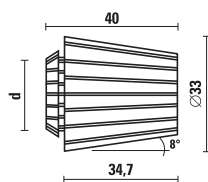

HP
>0,010

Item	d	Item	d
T134.030.N	Ø 3 - 2	T134.120.N	Ø 12 - 11
T134.040.N	Ø 4 - 3	T134.130.N	Ø 13 - 12
T134.050.N	Ø 5 - 4	T134.140.N	Ø 14 - 13
T134.060.N	Ø 6 - 5	T134.160.N	Ø 16 - 15
T134.070.N	Ø 7 - 6	T134.180.N	Ø 18 - 17
T134.080.N	Ø 8 - 7	T134.200.N	Ø 20 - 19
T134.100.N	Ø 10 - 9		

SPRING COLLETS ETS 40 - DIN 6499

ART. T135

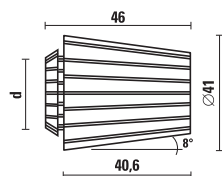

HP
>0,010

Item	d	Item	d
T135.040.N	Ø 4 - 3	T135.130.N	Ø 13 - 12
T135.050.N	Ø 5 - 4	T135.140.N	Ø 14 - 13
T135.060.N	Ø 6 - 5	T135.160.N	Ø 16 - 15
T135.070.N	Ø 7 - 6	T135.180.N	Ø 18 - 17
T135.080.N	Ø 8 - 7	T135.200.N	Ø 20 - 19
T135.100.N	Ø 10 - 9	T135.250.N	Ø 25 - 24
T135.120.N	Ø 12 - 11		

SPRING COLLET SET + WIPE OFF KIT



The **wipe off set** allows maintaining the inside as well as the seat of the spring collet on the chuck clean, helps increasing cutting efficiency and reduce vibrations for a longer tool life. No more risk of wrong positioning of both the collet and the tool due to chips and resin.

- In plastic box

Set complete with:
- nr. 10 spring collets
- Collet wipers
- Brushes for collet bore

Item	Item
	X125.515.N
	Set complete with 10 spring collets ER25: Ø3 - Ø4 - Ø5 - Ø6 - Ø7 Ø8 - Ø10 - Ø12 - Ø14 - Ø16

	T137.525.N - Collet wiper ER25
	X137.004.N - nr. 4 brushes for collet bore ER25

Item	Item
	X119.515.N
	Set complete with 10 spring collets ER32: Ø4 - Ø5 - Ø6 - Ø8 - Ø10 - Ø12 - Ø14 - Ø16 - Ø18 - Ø20

	T137.532.N - Collet wiper ER32
	X137.004.N - nr. 4 brushes for collet bore ER32

Item	Item
	X123.515.N
	Set complete with 10 spring collets ER40: Ø4 - Ø6 - Ø8 - Ø10 - Ø12 - Ø14 - Ø16 - Ø18 - Ø20 - Ø25

	T137.540.N - Collet wiper ER40
	X137.004.N - nr. 4 brushes for collet bore ER40

Item	Item
	X124.515.N
	Set complete with 10 spring collets DIN6388: Ø4 - Ø6 - Ø8 - Ø10 - Ø12 - Ø14 - Ø16 - Ø18 - Ø20 - Ø25

	T137.662.N - Collet wiper DIN6388-EOC25
	X137.004.N - nr. 4 brushes for collet bore DIN6388-EOC25

SET IN WOODEN BOX

ART. X118



Complete with concentric chuck ISO30 + 8 spring collets ER32

Item	X118.700.R	
complete with:	concentric chuck ISO 30/ER32 T118.700.R	
spring collets	Ø6	T119.060.N
	Ø8	T119.080.N
	Ø10	T119.100.N
	Ø12	T119.120.N
	Ø14	T119.140.N
	Ø16	T119.160.N
	Ø18	T119.180.N
	Ø20	T119.200.N

Item	X118.800.R	
complete with:	concentric chuck ISO 30/ER32 T118.800.R	
spring collets	Ø6	T119.060.N
	Ø8	T119.080.N
	Ø10	T119.100.N
	Ø12	T119.120.N
	Ø14	T119.140.N
	Ø16	T119.160.N
	Ø18	T119.180.N
	Ø20	T119.200.N

SET IN PLASTIC BOX

ART. X118



- Complete with concentric chuck HSK63F + 8 spring collets ER40

Item	X118.980.R	
complete with:	concentric chuck HSK63F/ER40 T118.980.R	
spring collets	Ø6	T123.060.N
	Ø8	T123.080.N
	Ø10	T123.100.N
	Ø12	T123.120.N
	Ø16	T123.160.N
	Ø18	T123.180.N
	Ø20	T123.200.N
	Ø25	T123.250.N

SET IN PLASTIC BOX

ART. X118



- Complete with concentric chuck HSK63F + 8 spring collets ER32

Item	X118.976.R	
complete with:	concentric chuck HSK63F/ER32 T118.976.R	
spring collets	Ø6	T119.060.N
	Ø8	T119.080.N
	Ø10	T119.100.N
	Ø12	T119.120.N
	Ø14	T119.140.N
	Ø16	T119.160.N
	Ø18	T119.180.N
	Ø20	T119.200.N

SET IN PLASTIC BOX

ART. X118



- Complete with concentric chuck HSK63F with ball bearing nut + 8 spring collets EOC25

Item	X118.984.R	
complete with:	concentric chuck HSK63F/EOC25 T118.984.R	
spring collets	Ø6	T124.060.N
	Ø8	T124.080.N
	Ø10	T124.100.N
	Ø12	T124.120.N
	Ø16	T124.160.N
	Ø18	T124.180.N
	Ø20	T124.200.N
	Ø25	T124.250.N

DUST & CHIP EXTRACTION NUT

ART. T139

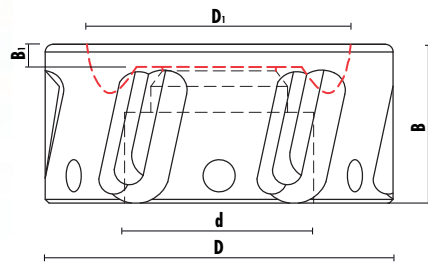

- Tool body in light alloy with a special surface coating against wear and corrosion for a maximum chips evacuation
- Optimal gap between Tornado® and material is 2 mm (0.078"). It works properly up to 10 mm (0.38")
- Smaller diameter: (92 mm) in order to be mounted on every CNC router/machining centre
- Suitable for every type of collet chuck (HSK, ISO, BT, ...)
- Maximum speed rotation at 20.000 RPM
- Balanced at G2,5, weight 0,256 kg

WATCH VIDEO



Item	Type	D	D1	B	B1	d	Rot.
T139.501.RK	DIN6499 (ER32)	92	70	40	6	M 40x1,5	RH
T139.502.RK	DIN6499 (ER40)	92	70	42	6	M 50x1,5	RH
T139.503.RK	DIN6499 (ER25)	92	70	42	6	M 32x1,5	RH
T139.522.RK	DIN6388 (EOC25)	92	70	42	6	M 48x2	RH
T139.581.RK	DIN6499 (ER32)	80	64	42	6	M 40x1,5	RH

DUST & CHIP EXTRACTION NUT SET

ART. X139



- Complete with:
n° 1 extraction nut
n° 1 hook wrench:
Ø 92= key 95/100
Ø 80= key 80/90
- Carton box

Item	Description	Type
X139.501.RK	T139.501.RK + Z052.315.N	DIN6499 (ER32)
X139.502.RK	T139.502.RK + Z052.315.N	DIN6499 (ER40)
X139.503.RK	T139.503.RK + Z052.315.N	DIN6499 (ER25)
X139.522.RK	T139.522.RK + Z052.315.N	DIN6388 (EOC25)
X139.581.RK	T139.581.RK + Z052.314.N	DIN6499 (ER32)

Tornado: the new dust & chips extraction nut helps both dust and chip evacuation during Nesting and conventional CNC Routing operations. Easy to assemble directly on the collet chuck instead of the standard nut, the new Klein Tornado® provides a big improvement of dust evacuation, removing it from the workpiece directly into the centralized extraction system of the CNC machines.

DUST & CHIP EXTRACTION NUT SET

ART. X139



- Complete with:
n° 2 extraction nuts (ER32-ER40)
n° 1 hook wrench 95/100
- Carton box

Item	Description
X139.990.RK	T139.501.RK + T139.502.RK + Z052.315.N

TORQUE WRENCHES FOR TORNADO

ART. Z052



Item	Type	L	Nm (draw. 1)	Nm (draw. 2)
Z052.722.N	ER25	480	40-55	80-90
Z052.723.N	ER32	480	66-70	120-130
Z052.724.N	ER40	480	110-120	190-200
Z052.728.N	EOC25	480	110-120	190-200

EASY TO MOUNT LIKE A STANDARD CLAMPING NUT

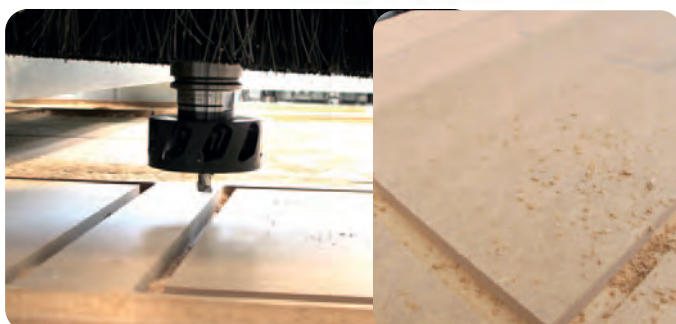

WORKING WITH TORNADO



WORKING WITHOUT TORNADO

TORQUE WRENCHES

While setting a tool it is extremely important to tighten it appropriately. **If not effectively tight indeed a cutting tool could slide away from the tool holder during the working process. On the other side, an excessive tightening can cause damages to the tool holder or spring collet or the tool itself.** The wrench indicates when the torque (Nm) is reached according to the value in the corresponding table.

TORQUE WRENCHES FOR "MINI" NUTS

You can find all spare parts in the section n. 10

ART. Z052

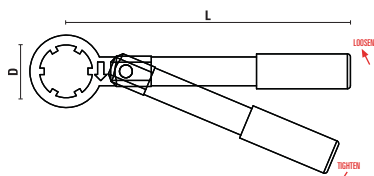

Item	D	L	Nm	Threaded nut
Z052.701.N	16	120	18	ER11
Z052.702.N	22	175	28	ER16
Z052.703.N	28	180	35	ER20
Z052.704.N	35	185	40	ER25

TORQUE WRENCHES FOR "STANDARD" NUTS

ART. Z052

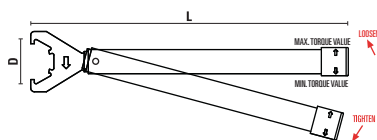

Dr. ①  Collets as per drawing n. 1 must be tightened by setting the minimum torque value and rotating the handle counterclockwise.

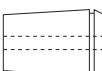
Dr. ②  Collets as per drawing n. 2 must be tightened by setting the maximum torque value and rotating the handle clockwise.

Item	D	L	Nm (Dr. 1)	Nm (Dr. 2)	Threaded nut
Z052.710.N	32	380	25-35	45-55	ER16
Z052.711.N	35	380	30-40	60-70	ER20
Z052.712.N	40	400	40-55	80-90	ER25
Z052.713.N	50	400	66-70	120-130	ER32
Z052.714.N	63	450	110-120	190-200	ER40

TORQUE HOOK WRENCHES

ART. Z052

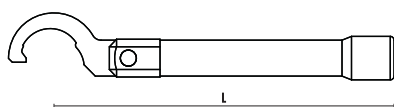

Dr. ①  Collets as per drawing n. 1 must be tightened by setting the minimum torque value and rotating the handle counterclockwise.

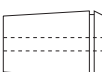
Dr. ②  Collets as per drawing n. 2 must be tightened by setting the maximum torque value and rotating the handle clockwise.

Item	D	L	Nm (Dr. 1)	Nm (Dr. 2)	Threaded nut
Z052.732.N	58-62	380	110-120	190-200	DIN 6388/EOC25
Z052.735.N	50	380	110-120	190-200	Z091.005.R

TORQUE WRENCHES FOR "NO-NOISE" NUTS

ART. Z052

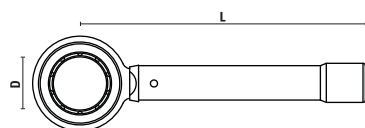

Dr. ①  Collets as per drawing n. 1 must be tightened by setting the minimum torque value and rotating the handle counterclockwise.

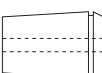
Dr. ②  Collets as per drawing n. 2 must be tightened by setting the maximum torque value and rotating the handle clockwise.

Item	D	L	Nm (Dr. 1)	Nm (Dr. 2)	Threaded nut
Z052.790.N	32	400	25-35	45-55	ER 16
Z052.793.N	50	400	65-70	120-130	ER 32
Z052.795.N	60	400	110-120	190-200	DIN 6388/EOC25

KEYS

ART. Z052

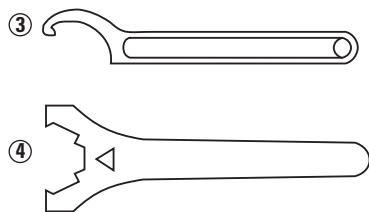

Item	Draw.	Threaded nut	Threaded nut
Z052.300.N	3	DIN6388/EOC12	Wrench 34/38
Z052.301.N	3	Z091.000.R	Wrench 40/42
Z052.305.N	3	Z091.005.R	Wrench 4850
Z052.310.N	3	DIN6388/EOC25	Wrench 58/62
Z052.314.N	3		Wrench for Tornado
Z052.315.N	3		Wrench for Tornado

Z052.401.N	4	ER 32
Z052.402.N	4	ER 40
Z052.404.N	4	ER 20
Z052.407.N	4	ER 25
Z052.409.N	4	ER 16

COLLET NUTS

ART. Z091

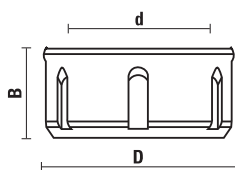

Item	Type	D	B	d	Rot.
Z091.000.R	For spring collets Art. T117	40	20	M 30x1,5	RH
Z091.000.L	For spring collets Art. T117	40	20	M 30x1,5	LH
Z091.001.R	DIN 6499 (ER 32)	50	23	M 40x1,5	RH
Z091.001.L	DIN 6499 (ER 32)	50	23	M 40x1,5	LH
Z091.002.R	DIN 6499 (ER 40)	63	25	M 50x1,5	RH
Z091.002.L	DIN 6499 (ER 40)	63	25	M 50x1,5	LH
Z091.005.R	For spring collets T133	50	23	M 40x1,5	RH
Z091.100.R	DIN 6499 (ER 25) ball bearing nut	42	20	M 32x1,5	RH/LH
Z091.101.R	DIN 6499 (ER 32) ball bearing nut	50	25	M 40x1,5	RH/LH
Z091.102.R	DIN 6499 (ER 40) ball bearing nut	63	27	M 50x1,5	RH/LH
Z091.103.R	DIN 6499 (ER 25)	42	20	M 32x1,5	RH
Z091.104.R	DIN 6499 (ER 20)	35	19	M 25x1,5	RH
Z091.105.R	DIN 6499 (ER 16)	32	17,5	M 22x1,5	RH
Z091.202.R	DIN 6388 (EOC25)	60	30	M 48x2	RH
Z091.203.R	DIN 6388 (EOC25) ball bearing nut	60	30	M 48x2	RH/LH
Z091.205.R	DIN 6388 (EOC12)	35	28	M 27x1,5	RH
Z091.301.R	ETS 32	50	22	M 40x1,5	RH
Z091.302.R	ETS 40	63	25	M 50x1,5	RH
Z091.403.R	ER 25 Type mini	35	20	M 30x1	RH
Z091.404.R	ER 20 Type mini	28	19	M 24x1	RH
Z091.405.R	ER 16 Type mini	22	18	M 19x1	RH
Z091.406.R	ER 11 Type mini	16	12	M 13x0,75	RH

WRENCHES FOR COLLET NUT "MINI"

ART. Z052

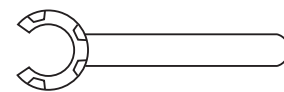

Item	Description
Z052.503.N	Wrench for collet nut ER 25 "mini" type
Z052.505.N	Wrench for collet nut ER 16 "mini" type
Z052.508.N	Wrench for collet nut ER 20 "mini" type
Z052.511.N	Wrench for collet nut ER 11 "mini" type

DUST PLUG

ART. Z051

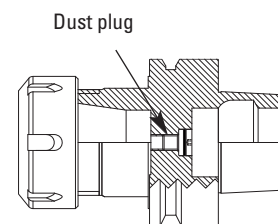
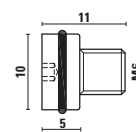

- To be used with our HSK toolholders to avoid any contamination of dust into the electrospindle.
- Inexpensive and easy to use.

Item	Description
Z051.070.N	M6x6 - hexagon head

"NO-NOISE" COLLET NUTS

ART. Z091

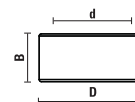

- Recommended when using router bits working at higher RPM
- Threaded nut with ground contours, remarkable reduction of noise

Item	Type	D	B	d	Rot.
Z091.501.R	DIN 6499 (ER 32)	50	23	M 40x1,5	RH
Z091.505.R	DIN 6499 (ER 16)	32	17,5	M 22x1,5	RH
Z091.522.R	DIN 6499 (EOC 25)	60	30	M 48x2	RH

You can find all spare parts in the section n. 10

RETAINING PAWLS FOR CONCENTRIC CHUCK

ART. T118

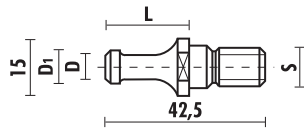

For: **Morbidelli, SCM**

Item	Type	D1	D	L	S
T118.790.R	ISO 30	8,5	6,5	22	M10

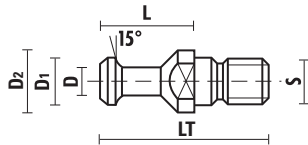

DIN 69872 for:
Anderson, Busellato, Weeke, Ima, Bulleri, Maka, Cosmec, Reichenbacher, Elte

Item	Type	D1	D2	D	L	LT	S
T118.791.R	ISO 30	13	17	9	24	44	M12
T118.893.R	ISO 40	19	23	14	26	54	M16

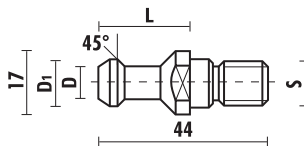

For: **Alberti, Vitap, Masterwood** (motor G. Colombo)

Item	Type	D1	D	L	S
T118.792.R	ISO 30	12,8	9	24	M12

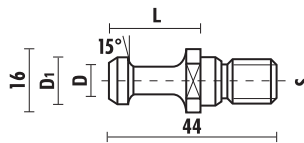

For: **Esseteam**

Item	Type	D1	D	L	S
T118.793.R	ISO 30	12	8	24	M12

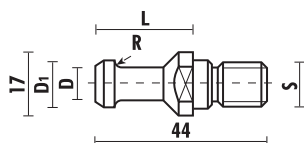

For: **CMS**

Item	Type	D1	D	L	R	S
T118.794.R	ISO 30	12,8	9	24	2,4	M12

RETAINING PAWLS FOR CONCENTRIC CHUCK

ART. T118

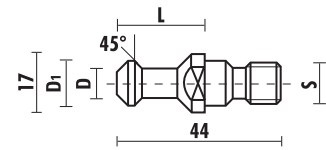

For: **Belotti**

Item	Type	D1	D	L	S
T118.795.R	ISO 30	13	9	23	M12

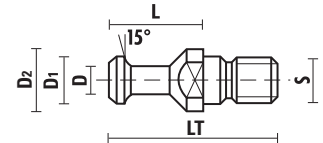

For: **Biesse** (until 9/9/92)

Item	Type	D1	D	L	S
T118.890.R	ISO 30	13	9	24	M12

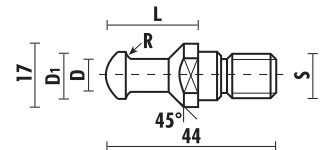

For: **Biesse** (after 9/9/92), **Masterwood, HSD spindle, Bulleri, Thermwood, Vitap, Hiteco**

Item	Type	D1	D	L	R	S
T118.891.R	ISO 30	12	8	24	3,2	M12

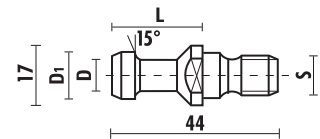

For: **Komo**

Item	Type	D1	D	L	S
T118.894.R	BT 30	13	9	24	M12

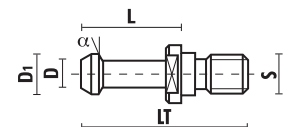

For: BT 30 - BT 40 **Shoda**, BT 35 **Heian**

Item	Type	D1	D	L	LT	α	S
T118.895.R	BT 30	11	7	23,5	43	30°	M12
T118.896.R	BT 35	13	8,5	28	48	45°	M12
T118.896.R030	BT 35	13	8,5	28	48	30°	M12
T118.897.R	BT 40	15	10	35	60	45°	M16

HOTBLOCK®

the new thermal shrink collet chucks are high precision collet chuck which ensure more precision having less coupling thanks to its special tight on the shank tool by thermal clamping. First, the collet tip is heated with a special heater unit, causing it to expand. The cutter shank is then inserted, and the collet is cooled to ambient temperature. This causes the collet to contract precisely around the cutter shank with a special eccentricity less than 3 micron, therefore the highest precision and stability for high performance and longer tool life.



SHRINK FIT CHUCKS HSK-63F

ART. T120



HotBlock®

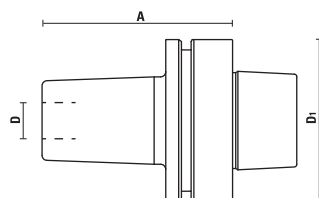

- The hollow taper shank is produced according to DIN69893
- **Concentricity $\leq 0,003$ mm**
- **High precision** tool holders guaranteed by thermally induced shrink fit
- High rigidity and balance for heavy CNC working
- For HS and HW cutting tool
- **Balanced to 24.000 RPM at G 2,5**
- **Right and left-hand rotation**
- Cutting tool shank must have tolerance h6 with cylindrical shank (no flats)
- Sold complete with certificate of balancing



Item	Taper	A	D1	D	Rot.
T120.564.N	HSK-63F	76	63	1/4" - (6,35 mm)	RH/LH
T120.580.N	HSK-63F	76	63	8	RH/LH
T120.595.N	HSK-63F	76	63	3/8" - (9,52 mm)	RH/LH
T120.600.N	HSK-63F	76	63	10	RH/LH
T120.620.N	HSK-63F	76	63	12	RH/LH
T120.627.N	HSK-63F	76	63	1/2" - (12,7 mm)	RH/LH
T120.660.N	HSK-63F	76	63	16	RH/LH
T120.695.N	HSK-63F	76	63	3/4" - (19,05 mm)	RH/LH
T120.700.N	HSK-63F	76	63	20	RH/LH
T120.750.N	HSK-63F	76	63	25	RH/LH

SHRINK FIT CHUCKS ISO 30

ART. T120



HotBlock®

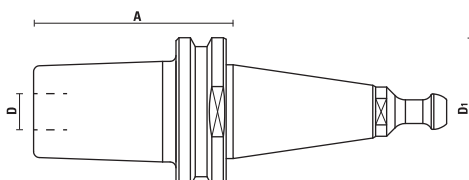

- The hollow taper shank is produced according to DIN69893
- **Concentricity $\leq 0,003$ mm**
- **High precision** tool holders guaranteed by thermally induced shrink fit
- High rigidity and balance for heavy CNC working
- For HS and HW cutting tool
- **Balanced to 24.000 RPM at G 2,5**
- **Right and left-hand rotation**
- Cutting tool shank must have tolerance h6 with cylindrical shank (no flats)
- Sold complete with certificate of balancing



- Retaining pawl T118.891.R for: **Biesse, Masterwood - Bulleri** (for H.S.D.), **Hiteco** included
- Other Retaining pawl can be fitted on request

Item	Taper	A	D1	D	Rot.
T120.320.N	ISO 30	76	50	12	RH/LH
T120.360.N	ISO 30	76	50	16	RH/LH
T120.400.N	ISO 30	76	50	20	RH/LH

SHRINK FIT CHUCK EXTENSIONS L=150

ART. T120

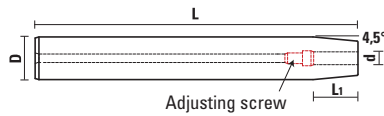

- Suitable for **working deep and hard to reach surfaces**
- To be used with heat shrink fit chucks (our item T120) or hydro chuck
- Best results when clamping HW or HS tools with h6 tool shank
- **With adjusting screw for length adjustment**

Item	D	d	L	L1	Screw
T120.012.03	12	3	150	12	M5
T120.012.04	12	4	150	16	M5
T120.016.04	16	4	150	16	M5
T120.016.06	16	6	150	26	M5
T120.020.06	20	6	150	26	M5
T120.020.08	20	8	150	26	M6
T120.020.10	20	10	150	32	M6
T120.020.12	20	12	150	37	M10
T120.025.08	25	8	150	26	M6
T120.025.10	25	10	150	32	M6
T120.025.12	25	12	150	37	M10
T120.025.16	25	16	150	40	M10

SHRINK FIT UNIT

ART. K.START.2



- **Heating time from 2 to 7 seconds**
- Provided with inductor stop rings (6 to 12) + (14 to 20) and chuck holder for HSK63F
- Heating located on the tool holder, no deterioration of the tool and tool holder
- **Self-regulated power** thanks to a microprocessor depending on parameters detected
- **Inductor rotates 180°** without disassembling
- Power supply 3x380/480V – 16A 50/60 Hz -14 kW
- Dimensions: L= 255 mm - D= 490 mm - H= 755 mm
- Weight (options excluded) 20 kgs

See this product at Section 16, page 16.18.

Item

K.START.2

NB: This items cannot be sold in Germany due to commercial agreements between the producer (Elco) and their autorised dealers in these markets.

COOLING UNIT WITH AIR FLOW

ART. K.FG500



- Air cooling unit for shrink fit chucks
- **Cooling time from 1,30 minute to 3 minutes**
- Provided with cooling stop rings (6 to 12) + (14 to 20) and chuck holder for HSK63F
- Compressed air supply: 4-6 bars
- Dimensions: L= 220 mm - D= 190 mm - H= 615 mm
- Weight: 5 kgs

See this product at Section 16, page 16.18.

Item

K.FG500

HSK63F HYDRO CHUCK

ART. T518

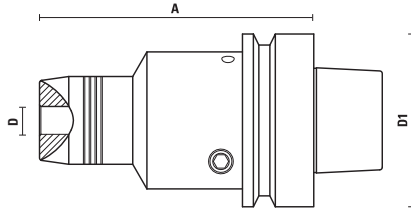

- **Concentricity** ≤ 0,005 mm
- Hexagonal T-key included
- **Precision balanced at G2.5 to 24.000 RPM**
- The hollow taper shank is produced according to DIN69893
- Tightening torque power of 5,5 N/m
- For right and left hand rotation

HydroBlock

MAIN ADVANTAGES OF HYDRAULIC CHUCK

- Reduced set up times thanks to an easy, quick and simple tool change
- More clamping force compared to collet chucks thus higher precision and better finishing of workpiece
- Less vibration during routing operation
- Very simple clamping operation
- Up to 2.500/3.000 tool changes without losing accuracy
- Longer tool lifetime
- Thanks to the reduction sleeves, a variety of shank sizes can be clamped
- Balanced at G 2.5 to 24.000 RPM



Item	A	D1	D	Rotation
T518.095.N100 NEW	100	63	3/8"	Dx-Sx/Rh-Lh
T518.120.N100 NEW	100	63	12	Dx-Sx/Rh-Lh
T518.127.N100 NEW	100	63	1/2"	Dx-Sx/Rh-Lh
T518.160.N100 NEW	100	63	16	Dx-Sx/Rh-Lh
T518.195.N100 NEW	100	63	3/4"	Dx-Sx/Rh-Lh
T518.200.N100 NEW	100	63	20	Dx-Sx/Rh-Lh
T518.120.N NEW	80	63	12	Dx-Sx/Rh-Lh
T518.160.N NEW	80	63	16	Dx-Sx/Rh-Lh
T518.200.N NEW	80	63	20	Dx-Sx/Rh-Lh
T518.250.N NEW	85	63	25	Dx-Sx/Rh-Lh

REDUCTION SLEEVES FOR HYDRO CHUCKS

ART. T521

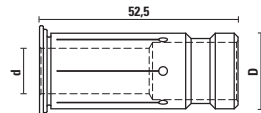

- These sleeves allow clamping of different diameters with just one hydro chuck
- Suitable for all common cutting tools with cylindrical shank



Item	D	d
T521.120.030 NEW	12	3
T521.120.040 NEW	12	4
T521.120.050 NEW	12	5
T521.120.060 NEW	12	6
T521.120.080 NEW	12	8
T521.120.100 NEW	12	10

Item	D	d
T521.200.060 NEW	20	6
T521.200.080 NEW	20	8
T521.200.100 NEW	20	10
T521.200.120 NEW	20	12
T521.200.140 NEW	20	14
T521.200.160 NEW	20	16
T521.200.180 NEW	20	18

Item	D	d
T521.250.060 NEW	25	6
T521.250.080 NEW	25	8
T521.250.100 NEW	25	10
T521.250.120 NEW	25	12
T521.250.140 NEW	25	14
T521.250.160 NEW	25	16
T521.250.180 NEW	25	18
T521.250.200 NEW	25	20

HydroBlock®

FUNCTIONAL DESCRIPTION

The hydraulic expansion chucks perform tool clamping hydraulically by manually driving the internal piston through the clamping screw. To achieve maximum clamping force on the tool, the screw must be tightened all the way. **Tightening the screw activates the internal hydraulic mechanism, pushing the volume of oil inside and pressing it in measured amounts against the internal thin walls of the sealed chamber, which will expand causing the tool to clamp optimally and uniformly.** The benefits are therefore considerable, greatly reducing vibration and improving machining quality. Unscrewing the screw, on the other hand, causes a reduction in oil pressure on the thin walls of the sealed expansion chamber and thus the release of the tool.

SISTEMI has chosen to produce and place on the market two versions of the HSK63F hydraulic chuck: a more compact one (A=80 mm) and an extended one (A=100 mm), with nominal diameters in both millimeters and inches so as to satisfy every request of our customers. Such a wide range enables us to offer a guaranteed and extremely precise product.

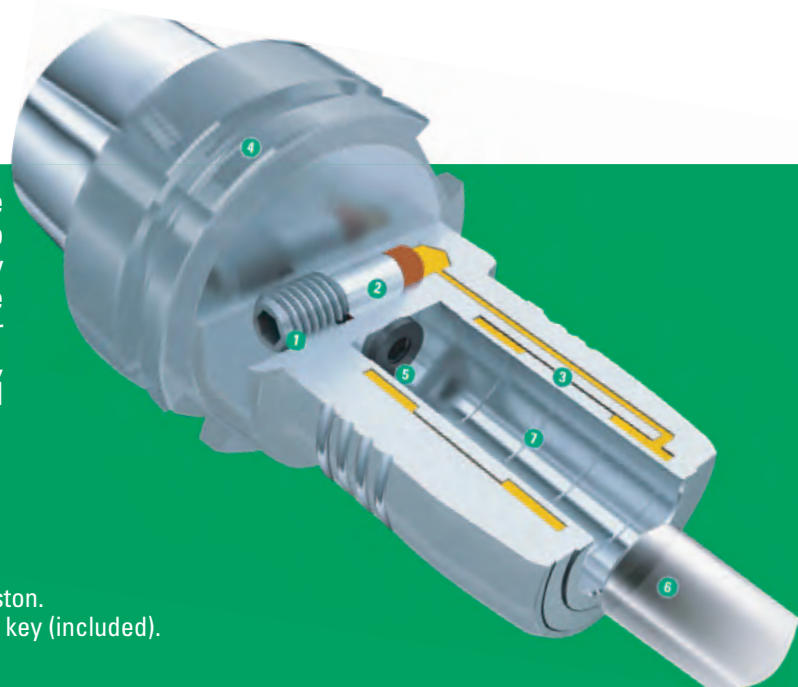

With a few simple action, the tool can be changed quickly and easily. Insert the tool into the hydraulic toolholder, with an Allen key (included) tighten the clamping screw to the end - chuck is now ready to be used! Your advantage: time savings, reduced set-up time, no extra investment in additional devices and machines.

TECHNICAL FEATURES

1. Clamping screw

The clamping screw is used to move the clamping piston.
Tighten the clamping screw to the end using an Allen key (included).

2. Clamping piston

The clamping piston compresses the hydraulic fluid into the oil system.

3. Expansion sleeve and oil system

The expansion sleeve expands itself against the tool shank. The tool shank is centered first and then clamped powerfully and evenly across the entire surface. Cutting edge wear is thus dramatically reduced and tool life is increased by up to 40%.

4. Taper part

The hollow taper shank is produced according to DIN 69893.

5. Threaded through hole (M5)

6. Cutter shank

The tool is centrally clamped to the center axis ensuring highest run-out and concentricity of $\leq 0,005$ mm.
Cutting tool must have h6 tolerance.

7. Dirt grooves

Specially created to collect dirt (oil and grease residues) while keeping the rest of the surface dry.



View
ONLINE

ADAPTERS FOR CIRCULAR SAWBLADES

ART. T128

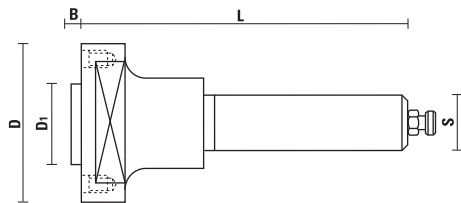

- Nr. 4 pin holes with M6/90°
- Complete with nr. 4 screws to fix the sawblade
- Recommended to use sawblades with diameters between 150 and 200 mm
- Item T128.143.R (S=16) is especially made to be mounted on aggregate heads

Item	D	D1	B	S	L	Pin holes
T128.141.R	60	22	2,5	Ø20x60	90	4/4/36
T128.140.R	60	30	2,5	Ø20x60	90	4/6/48
T128.143.R	60	30	2,5	Ø16x50	85	4/6/48
T128.145.R	60	30	2,5	Ø25x60	90	4/6/48



Z051.018.R
(T128.141.R)



Z051.014.R
(T128.140/3/5.R)



Z051.506.R

ISO 30 ADAPTERS FOR CIRCULAR SAWBLADES

ART. T128

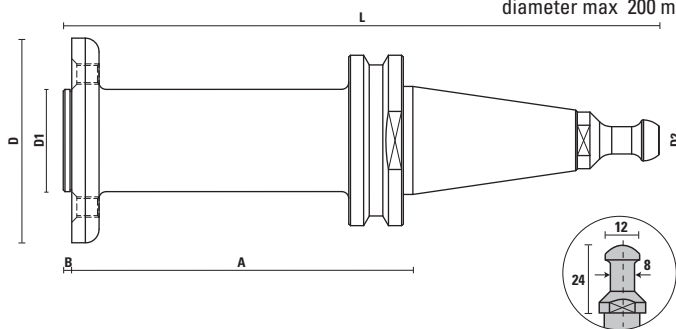

- Nr. 4 pin holes 90°
- Complete with nr. 4 screws to fix the sawblade
- For mounting saw blades with 30 mm bore
- For mounting saw blades with diameter max 200 mm

- Retaining pawl T118.891.R for: **Biesse**

Item	Taper	A	D	D1	D2	B	L
T128.150.R	ISO 30	100	60	30	50	2,5	174



Z051.014.R

HSK-63E ADAPTORS FOR LARGE DIAMETER SAWBLADES

ART. T128

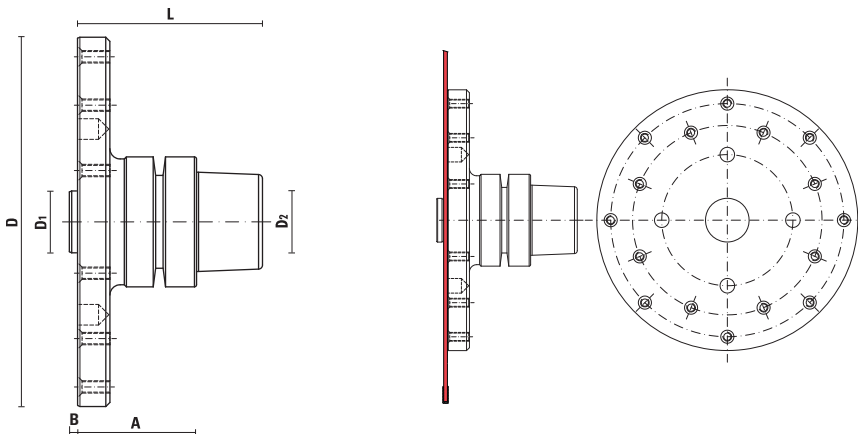

- For mounting sawblades with 30 mm bore
- For mounting sawblades with diameter up to 850 mm
- Supplied complete with 16 counterscrews M6 for mounting saw blades (part number Z051.014.N)

For: **Uniteam**

Item	Taper	A	D	D1	D2	B	L
T128.180.R	HSK-63E	57	179	30	63	4	89



Z051.014.R

HSK-63 ADAPTERS FOR CIRCULAR SAWBLADES

ART. T128

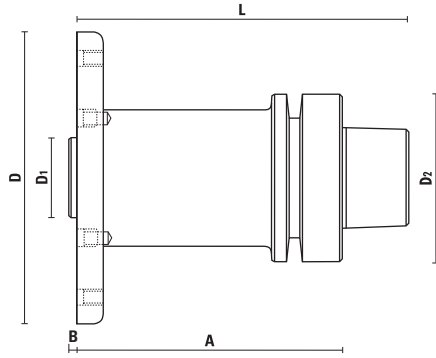

- The hollow taper shank is produced according to DIN69893
- Complete with nr. 6 screws (M6x10) for the proper assembly of sawblades with 60° at 90 mm distance
- For mounting sawblades with 30 mm bore
- **For mounting sawblades with diameter between 200 and 350 mm**



Item	Taper	A	D	D1	D2	B	L
T128.160.R	HSK-63F	40	110	30	63	2,5	65
T128.165.R	HSK-63F	100	110	30	63	2,5	125
T128.170.R	HSK-63E	40	110	30	63	2,5	72
T128.175.R	HSK-63E	100	110	30	63	2,5	132



Z051.014.R

EXAMPLE OF USE:
HSK63 adapter with mounted Saw Blade

OPTIONS:
Security flange (item Z092.100.N) to secure sawblades with maximum diameter of 400 mm by changing screws.

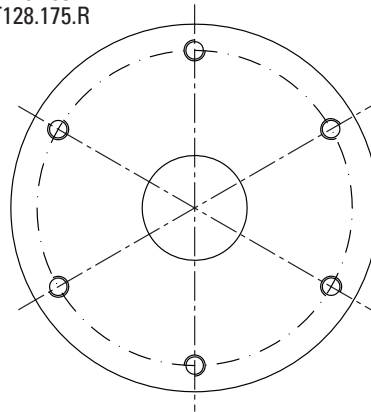
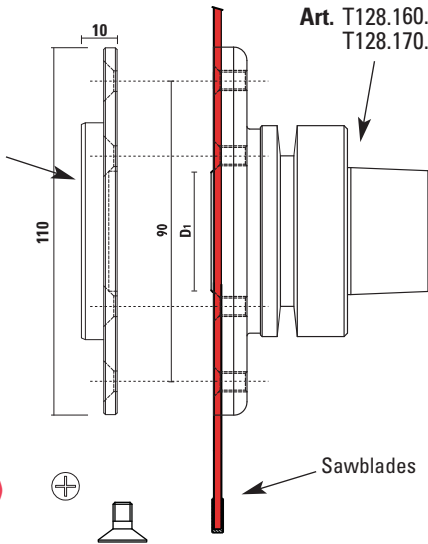

Go to page 12.30 to see the range of sawblades for these adaptors



SCREW (ART. Z051.014.R)
M6x10 countersunk flat head screw

SECURITY FLANGE FOR SAW BLADES ADAPTERS

ART. Z092

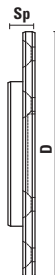

- To be used with our adapters, see items T128.160/165.R - T128.170/175.R
- **Security flange improves stability and reduces vibrations when precision cuts are needed**
- Complete with nr. 6 screws for the proper assembly of the sawblades with 60° at 90 mm distance
- **Maximum sawblades diameter of 400 mm**

ATTENTION:

Replace the adapters screws with those provided with the security flange.

Item	D	Sp
Z092.100.N	110	10



Z051.024.R

HSK-63F DRILL CHUCK FOR CNC

ART. T118

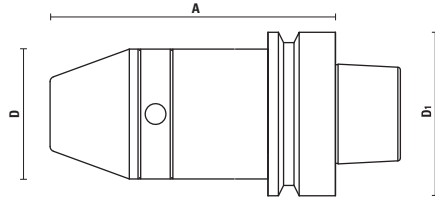

- The hollow taper shank is produced according to DIN69893
- For CNC drilling operation
- The special one-piece design guarantees best precision and greater rigidity
- Supplied with key
- Concentricity < 0,02 mm
- Capacity from 1 mm (1/16") to 13 mm (1/2")

BALLUFF
POCKET

Item	Taper	A	D	D1	Capacity	Rot.
T118.915.N	HSK-63F	110	50	63	1-13 mm	RH/LH



Z052.071.N

HOW TO CLAMP THE TOOL

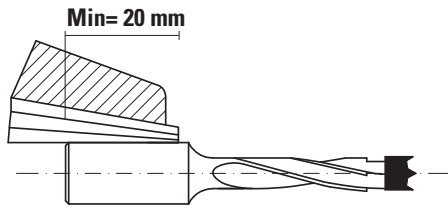

- Do not clamp tapered shanks
- Minimum clamping length is 20 mm and maximum is 29 mm
- Use feed and RPM suitable for drilling

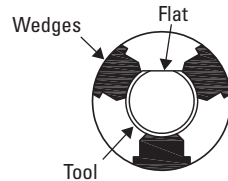

- If possible use cylindrical shanks
- If you use shank with flat, the clamping wedges are not allowed to touch the flat (see drawing)



How to clamp the tool with key

QUICK CHANGE ISO 30 TAPPING CHUCK

ART. UT118

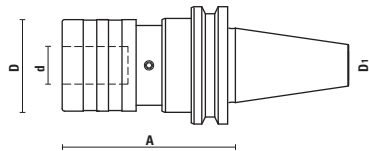

- For making threads in aluminium machining
- With axial compensation
- To be used with bushes for tapping with outer diameter D=19 mm DIN 352, DIN 371, DIN 376
- Supplied without pull stud
- For tapping operation on CNC machines

Item	Taper	A	d	D	D1
UT118.080.N	ISO 30	74	19	39	50

QUICK CHANGE HSK-63F TAPPING CHUCK

ART. UT118

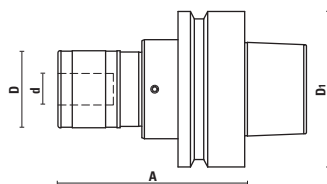

- The hollow taper shank is produced according to DIN69893
- For making threads in aluminium machining
- With axial compensation
- To be used with bushes for tapping with outer diameter D=19 mm DIN 352, DIN 371, DIN 376
- For tapping operation on CNC machines

BALLUFF
POCKET

Item	Taper	A	d	D	D1
UT118.090.N	HSK-63F	81	19	39	63

QUICK CHANGE BUSHES FOR TAPPING (DIN 371)

ART. UT100

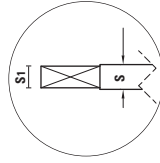
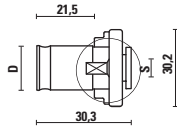

Thread tap shank with square

- Suitable for tapping of through holes
- **High precision**, suitable for processing aluminium
- For mounting taps ("M" series)

Item	Thread	D	S= ∅Shank	S1= □Square	Rot.
UT100.030.N	M3	19	3,5	2,7	RH/LH
UT100.035.N	M3,5	19	4	3,15	RH/LH
UT100.040.N	M4	19	4,5	3,4	RH/LH
UT100.050.N	M5	19	6	4,9	RH/LH
UT100.060.N	M6	19	6	4,9	RH/LH
UT100.080.N	M8	19	8	6,2	RH/LH
UT100.100.N	M10	19	10	8	RH/LH
UT100.120.N	M12	19	9	7	RH/LH

QUICK CHANGE BUSHES FOR TAPPING (DIN 371) WITH SAFETY CLUTCH

ART. UT105

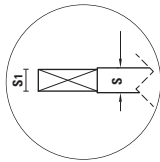
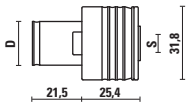

Thread tap shank with square

- Suitable for tapping of blind holes
- **High precision**, suitable for processing aluminium
- For mounting taps and prevents their breakage due to the safety clutch
- For mounting taps ("M" series)

Item	Thread	D	S= ∅Shank	S1= □Square	Rot.
UT105.030.N	M3	19	3,5	2,7	RH/LH
UT105.035.N	M3,5	19	4	3,15	RH/LH
UT105.040.N	M4	19	4,5	3,4	RH/LH
UT105.050.N	M5	19	6	4,9	RH/LH
UT105.060.N	M6	19	6	4,9	RH/LH
UT105.080.N	M8	19	8	6,2	RH/LH
UT105.100.N	M10	19	10	8	RH/LH
UT105.120.N	M12	19	9	7	RH/LH

EXAMPLE OF ASSEMBLY

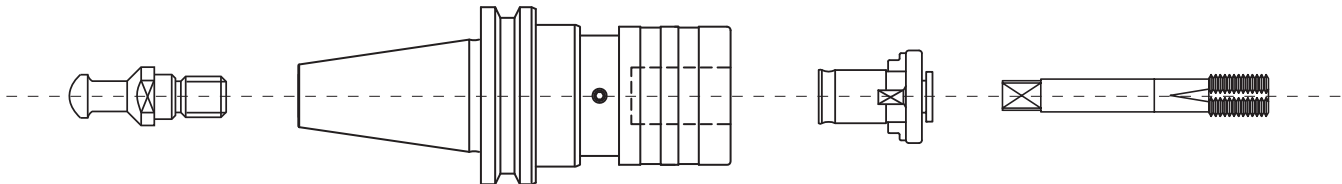

CUTTER ARBORS WITH ISO 30 TAPER

ART. T128

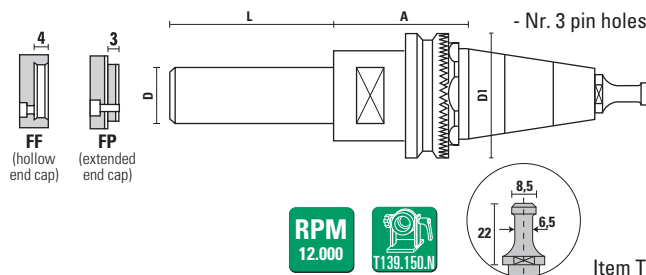

- Complete with retaining pawl page 7.39 and end cap page 10.14

- Nr. 3 pin holes to 120°

Item T118.790.R for: **Morbidelli, SCM**

Item	Taper	A	D	D1	L	End cap
T128.690.N	ISO 30	39	30	49	70	FF - Z092.001.R
T128.700.N	ISO 30	39	30	49	100	FF - Z092.001.R
T128.690.NM	ISO 30	39	30	49	70	FP - Z092.002.R
T128.700.NM	ISO 30	39	30	49	100	FP - Z092.002.R



Z051.016.R

CUTTER ARBORS WITH ISO 30 - ISO 40 TAPER

ART. T128

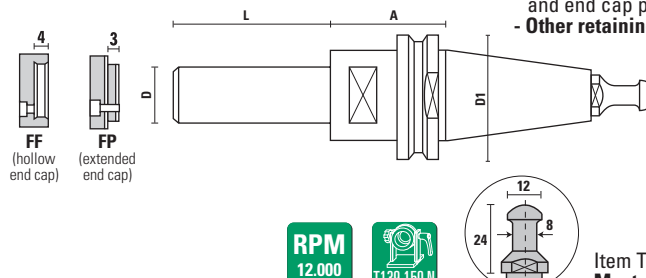

- Complete with retaining pawl page 7.39 and end cap page 10.14

- Other retaining pawl on request

Item T118.891.R for: **Biesse** (after 09/09/92), **HSD spindle, Masterwood - Bulleri, Vitap, Hiteco**

Item	Taper	A	D	D1	L	End cap
T128.790.N	ISO 30	35	30	50	70	FF - Z092.001.R
T128.800.N	ISO 30	35	30	50	100	FF - Z092.001.R
T128.790.NM	ISO 30	35	30	50	70	FP - Z092.002.R
T128.800.NM	ISO 30	35	30	50	100	FP - Z092.002.R
T128.800.N120	ISO 30	35	30	50	120	FF - Z092.001.R
T128.800.N120M	ISO 30	35	30	50	120	FP - Z092.002.R

Retaining pawl T118.792.R for: **Alberti, Vitap, Masterwood** (motor G. Colombo)

Item	Taper	A	D	D1	L	End cap
T128.791.N	ISO 30	35	30	50	70	FF - Z092.001.R
T128.801.N	ISO 30	35	30	50	100	FF - Z092.001.R
T128.791.NM	ISO 30	35	30	50	70	FP - Z092.002.R
T128.801.NM	ISO 30	35	30	50	100	FP - Z092.002.R

Retaining pawl T118.791.R (DIN 69872) for: **Busellato, Weeke, Ima, Bulleri, Maka, Cosmec, Reichenbacher, Elte**

Item	Taper	A	D	D1	L	End cap
T128.792.N	ISO 30	35	30	50	70	FF - Z092.001.R
T128.802.N	ISO 30	35	30	50	100	FF - Z092.001.R
T128.792.NM	ISO 30	35	30	50	70	FP - Z092.002.R
T128.802.NM	ISO 30	35	30	50	100	FP - Z092.002.R

Retaining pawl T118.893.R for: **Ima, Weeke, Maka, Reichenbacher, Stegherr**

Item	Taper	A	D	D1	L	End cap
T128.850.N	ISO 40	35	30	63,5	100	FF - Z092.001.R
T128.850.NM	ISO 40	35	30	63,5	100	FP - Z092.002.R



Z051.016.R

CUTTER ARBORS WITH HSK-63F TAPER

ART. T128

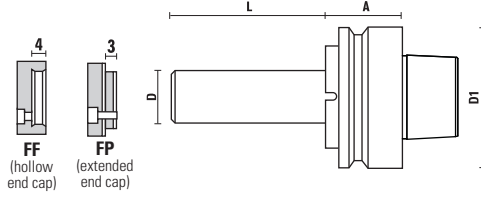

- The hollow taper shank is produced according to DIN69893
- Complete with end cap page 10.14
- Nr. 3 pin holes to 120°



Item	Taper	A	D	D1	L	End cap
T128.970.R	HSK-63F	33	30	63	70	FF - Z092.001.R
T128.970.RM	HSK-63F	33	30	63	70	FP - Z092.002.R
T128.980.R	HSK-63F	33	30	63	100	FF - Z092.001.R
T128.980.RM	HSK-63F	33	30	63	100	FP - Z092.002.R
T128.980.R050M	HSK-63F	33	30	63	50	FP - Z092.002.R
T128.980.R060M	HSK-63F	33	30	63	60	FP - Z092.002.R
T128.980.R065M	HSK-63F	33	30	63	65	FP - Z092.002.R
T128.980.R075M	HSK-63F	33	30	63	75	FP - Z092.002.R
T128.980.R080M	HSK-63F	33	30	63	80	FP - Z092.002.R
T128.980.R085M	HSK-63F	33	30	63	85	FP - Z092.002.R
T128.980.R090M	HSK-63F	33	30	63	90	FP - Z092.002.R
T128.980.R095M	HSK-63F	33	30	63	95	FP - Z092.002.R
T128.980.R105M	HSK-63F	33	30	63	105	FP - Z092.002.R
T128.980.R110M	HSK-63F	33	30	63	110	FP - Z092.002.R
T128.980.R115M	HSK-63F	33	30	63	115	FP - Z092.002.R
T128.980.R120M	HSK-63F	33	30	63	120	FP - Z092.002.R
T128.980.R125M	HSK-63F	33	30	63	125	FP - Z092.002.R
T128.980.R130M	HSK-63F	33	30	63	130	FP - Z092.002.R
T128.980.R135M	HSK-63F	33	30	63	135	FP - Z092.002.R
T128.980.R140M	HSK-63F	33	30	63	140	FP - Z092.002.R
T128.980.R145M	HSK-63F	33	30	63	145	FP - Z092.002.R
T128.980.R150M	HSK-63F	33	30	63	150	FP - Z092.002.R
T128.980.R160M	HSK-63F	33	30	63	160	FP - Z092.002.R
T128.980.R170M	HSK-63F	33	30	63	170	FP - Z092.002.R
T128.980.R180M	HSK-63F	33	30	63	180	FP - Z092.002.R
T128.980.R200M	HSK-63F	33	30	63	200	FP - Z092.002.R
T128.980.1x125M	HSK-63F	33	1"	63	125	FP - Z092.008.R
T128.980.1,25x125M	HSK-63F	33	1-1/4"	63	125	FP - Z092.010.R
T128.980.35x100	HSK-63F	33	35	63	100	FF - Z092.003.R
T128.980.35x100M	HSK-63F	33	35	63	100	FP - Z092.004.R
T128.980.40x100	HSK-63F	33	40	63	100	FF - Z092.005.R
T128.980.40x100M	HSK-63F	33	40	63	100	FP - Z092.006.R
T128.972.R	HSK-63F	42	30	63	70	FF - Z092.001.R
T128.972.RM	HSK-63F	42	30	63	70	FP - Z092.002.R
T128.982.R	HSK-63F	42	30	63	100	FF - Z092.001.R
T128.982.RM	HSK-63F	42	30	63	100	FP - Z092.002.R
T128.982.R080	HSK-63F	42	30	63	80	FF - Z092.001.R
T128.982.R080M	HSK-63F	42	30	63	80	FP - Z092.002.R
T128.982.R125	HSK-63F	42	30	63	125	FF - Z092.001.R
T128.982.R125M	HSK-63F	42	30	63	125	FP - Z092.002.R
T128.982.1,25x125M	HSK-63F	42	1-1/4"	63	125	FP - Z092.010.R
T128.982.35x100	HSK-63F	42	35	63	100	FF - Z092.003.R
T128.982.35x100M	HSK-63F	42	35	63	100	FP - Z092.004.R



Z051.016.R

CUTTER ARBORS WITH HSK-63E TAPER

ART. T128

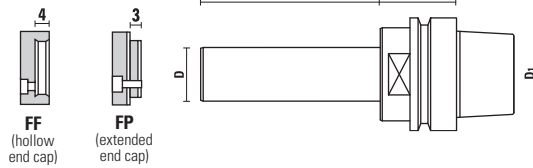

- The hollow taper shank is produced according to DIN69893
- Complete with end cap page 10.14
- Nr. 3 pin holes to 120°

RPM
12.000

T139.163.N

BALLUFF
POCKET

Item	Taper	A	D	D1	L	End cap
T128.988.R	HSK-63E	42	30	63	100	FF - Z092.001.R
T128.988.RM	HSK-63E	42	30	63	100	FP - Z092.002.R
T128.988.R140M	HSK-63E	42	30	63	140	FP - Z092.002.R
T128.988.R160M	HSK-63E	42	30	63	160	FP - Z092.002.R
T128.988.R180M	HSK-63E	42	30	63	180	FP - Z092.002.R
T128.988.R190M	HSK-63E	42	30	63	190	FP - Z092.002.R
T128.988.R220M	HSK-63E	42	30	63	220	FP - Z092.002.R
T128.988.R230M	HSK-63E	42	30	63	230	FP - Z092.002.R
T128.988.35x100	HSK-63E	42	35	63	100	FF - Z092.003.R
T128.988.35x100M	HSK-63E	42	35	63	100	FP - Z092.004.R
T128.988.35x130M	HSK-63E	42	35	63	130	FP - Z092.004.R
T128.988.35x150M	HSK-63E	42	35	63	150	FP - Z092.004.R
T128.988.35x180M	HSK-63E	42	35	63	180	FP - Z092.004.R
T128.988.35x200M	HSK-63E	42	35	63	200	FP - Z092.004.R
T128.988.40x100	HSK-63E	42	40	63	100	FF - Z092.005.R
T128.988.40x100M	HSK-63E	42	40	63	100	FP - Z092.006.R
T128.988.40x150M	HSK-63E	42	40	63	150	FP - Z092.006.R
T128.988.40x200M	HSK-63E	42	40	63	200	FP - Z092.006.R



Z051.016.R

LIFTING FLANGE FOR CUTTER ARBORS

ART. Z092

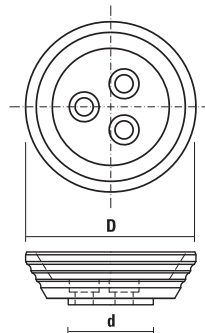

It mounts in place of the standard end cap to simplify the handling of heavy cutter stock

Item	d	D
Z092.030.N NEW	40	80

CUTTER ARBORS WITH HSK-85 TAPER

ART. T130 - T131 - T132

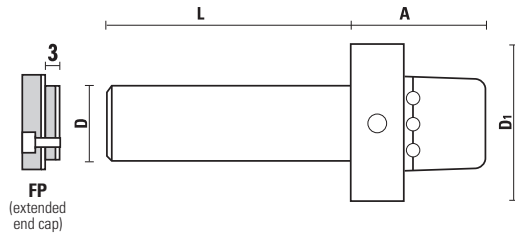

- The hollow taper shank is produced according to DIN69893
- Complete with end cap page 10.14
- Nr. 3 pin holes to 120°

RPM
12.000

T139.185.N

BALLUFF
POCKET

for: **Weinig Powerlock system**

Item	Taper	A	D	D1	L	End cap
T130.060.N	HSK-85	58	30	85	60	FP - Z092.002.R
T130.080.N	HSK-85	58	30	85	80	FP - Z092.002.R
T130.100.N	HSK-85	58	30	85	100	FP - Z092.002.R
T130.130.N	HSK-85	58	30	85	130	FP - Z092.002.R
T130.150.N	HSK-85	58	30	85	150	FP - Z092.002.R
T130.180.N	HSK-85	58	30	85	180	FP - Z092.002.R
T130.200.N	HSK-85	58	30	85	200	FP - Z092.002.R
T130.230.N	HSK-85	58	30	85	230	FP - Z092.002.R
T130.240.N	HSK-85	58	30	85	240	FP - Z092.002.R
T131.080.N	HSK-85	58	35	85	80	FP - Z092.004.R
T131.100.N	HSK-85	58	35	85	100	FP - Z092.004.R
T131.120.N	HSK-85	58	35	85	120	FP - Z092.004.R
T131.150.N	HSK-85	58	35	85	150	FP - Z092.004.R
T131.200.N	HSK-85	58	35	85	200	FP - Z092.004.R
T132.060.N	HSK-85	58	40	85	60	FP - Z092.006.R
T132.080.N	HSK-85	58	40	85	80	FP - Z092.006.R
T132.100.N	HSK-85	58	40	85	100	FP - Z092.006.R
T132.130.N	HSK-85	58	40	85	130	FP - Z092.006.R
T132.150.N	HSK-85	58	40	85	150	FP - Z092.006.R
T132.180.N	HSK-85	58	40	85	180	FP - Z092.006.R
T132.200.N	HSK-85	58	40	85	200	FP - Z092.006.R
T132.240.N	HSK-85	58	40	85	240	FP - Z092.006.R



Z051.016.R

CUTTER ARBORS WITH HSK-85S TAPER

ART. T132



- The hollow taper shank is produced according to DIN69893
- Complete with end cap page 10.14
- Nr. 3 pin holes to 120°

RPM
12.000

T139.185.N

BALLUFF
POCKET

for: **SCM**

Item	Taper	A	D	D1	L	End cap
T132.320.NS	HSK-85S	58	50	85	320	FF - Z092.050.R



Z051.016.R

SPACERS 2-SIDES GRINDED

ART. YD300 - YD350 - YD400 - YD500 - YD600

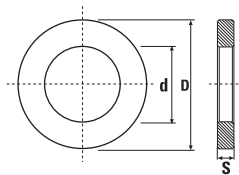

- For arbors Art. T128 - Art. T130 - Art. T131 - Art. T132
- Burnished
- **Spacer rings fine-blanking processed for thickness 0,1÷1 mm (tolerance ± 0,02)**
- **Spacer rings grinded on two sides for thickness 2÷50 mm (tolerance ± 0,01)**

Item	d	D	S
YD300.001	30	50	0,1
YD300.002	30	50	0,2
YD300.005	30	50	0,5
YD300.010	30	50	1
YD300.020	30	50	2
YD300.030	30	50	3
YD300.040	30	50	4
YD300.050	30	50	5
YD300.060	30	50	6
YD300.080	30	50	8
YD300.100	30	50	10
YD300.120	30	50	12
YD300.150	30	50	15
YD300.200	30	50	20
YD300.250	30	50	25
YD300.300	30	50	30
YD300.400	30	50	40
YD300.500	30	50	50
YD350.001	35	55	0,1
YD350.002	35	55	0,2
YD350.005	35	55	0,5
YD350.010	35	55	1
YD350.020	35	55	2
YD350.030	35	55	3
YD350.040	35	55	4
YD350.050	35	55	5
YD350.060	35	55	6
YD350.080	35	55	8
YD350.100	35	55	10
YD350.120	35	55	12
YD350.150	35	55	15
YD350.200	35	55	20
YD350.250	35	55	25
YD350.300	35	55	30
YD350.400	35	55	40
YD350.500	35	55	50

Item	d	D	S
YD400.001	40	60	0,1
YD400.002	40	60	0,2
YD400.005	40	60	0,5
YD400.010	40	60	1
YD400.020	40	60	2
YD400.030	40	60	3
YD400.040	40	60	4
YD400.050	40	60	5
YD400.060	40	60	6
YD400.080	40	60	8
YD400.100	40	60	10
YD400.120	40	60	12
YD400.150	40	60	15
YD400.200	40	60	20
YD400.250	40	60	25
YD400.300	40	60	30
YD400.400	40	60	40
YD400.500	40	60	50
YD500.001	50	70	0,1
YD500.002	50	70	0,2
YD500.005	50	70	0,5
YD500.010	50	70	1
YD500.020	50	70	2
YD500.030	50	70	3
YD500.040	50	70	4
YD500.050	50	70	5
YD500.060	50	70	6
YD500.080	50	70	8
YD500.100	50	70	10
YD500.120	50	70	12
YD500.150	50	70	15
YD500.200	50	70	20
YD500.250	50	70	25
YD500.300	50	70	30
YD500.400	50	70	40
YD500.500	50	70	50
YD600.001	60	80	0,1
YD600.002	60	80	0,2
YD600.005	60	80	0,5
YD600.010	60	80	1
YD600.020	60	80	2
YD600.030	60	80	3
YD600.040	60	80	4
YD600.050	60	80	5
YD600.060	60	80	6
YD600.080	60	80	8
YD600.100	60	80	10
YD600.120	60	80	12
YD600.150	60	80	15
YD600.200	60	80	20
YD600.250	60	80	25
YD600.300	60	80	30
YD600.400	60	80	40
YD600.500	60	80	50



SPACERS SET

ART. YD300 - YD350 - YD400 - YD500 - YD600

Item	d	D
YD300.990	30	50
YD350.990	35	55
YD400.990	40	60
YD500.990	50	70
YD600.990	60	80

Complete with:

- nr. 4 sp. 2 mm - nr. 3 sp. 4 mm - nr. 2 sp. 5 mm
- nr. 2 sp. 10 mm - nr. 1 sp. 20 mm - nr. 1 sp. 30 mm

PRECISION TEST BARS

ART. T501

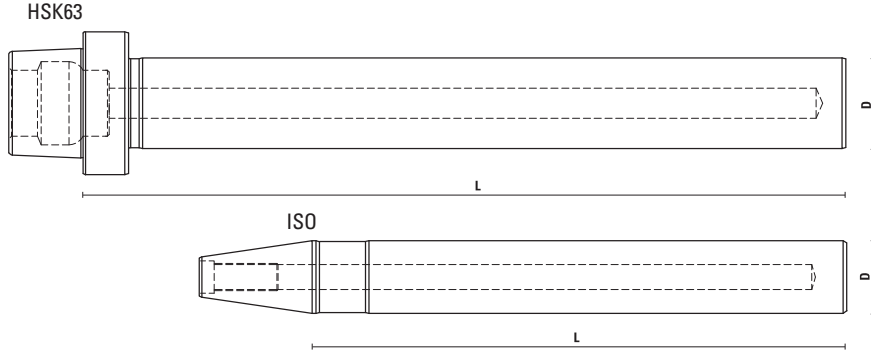

- Maximum runout error 0,003 mm/3 micron/0.0001 inch
- With certificate of calibration included
- Comes with sturdy wooden case to protect
- ISO30 type, supplied without pull stud

Item	Taper	D	L
T501.080.N	ISO30	32	235
T501.090.N	HSK63F	40	335
T501.095.N	HSK63E	40	335



WHY USE THE PRECISION TEST BARS?

- Produced with accurate quality control system
- **Allows to inspect the electrospindle with extreme precision and identify any problems**
- **It is possible to check both concentricity, parallelism and alignments of the spindle of your CNC machine**
- Thanks to a regular use of our test bars, machine anomalies can be found with no risk of compromising the spindle, avoiding costly down time
- Especially lightened internally for greater efficiency.

MACHINES AND TOOLS MAINTENANCE:

Clean collets and tool holders regularly before inserting the cutting tool. Regular cleaning increases the operation safety and ensures great performance. We recommend a regular preventive maintenance of the spindle mouth, collet pocket and spring collets using the right wipers and brushes thanks to our item X137. In order to prevent the formation of corrosion and rust, tool holders and spring collets have to be treated with a protective lubricant before storing them (see our item KleinPROTECT). Any dirt, dust, oil or other contaminant left on the spindle, taper, flange or collet can cause poor TIR (runout) and premature wear. It is necessary to protect your investments in machines with a regular cleaning.

SPINDLE WIPERS

ART. T137

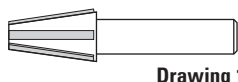

Drawing 1

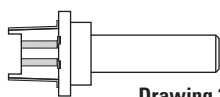

Drawing 2

- To maintain the inside of the spindle mouth clean
- Ensures extreme cleanliness of tapered spindles and it maintains the precision and prolongs the life of your expensive machines, cutting tools and toolholders
- To avoid **wrong positioning of the holders and ensure best contact between tool and tool holder for a better coupling**
- Suitable for all tool holder types
- A **proper maintenance** of the collet and the spindle with Klein® products will allow your tooling to live longer with better performance

Item	Concentric chuck	Drawing
T137.002.N	Taper 2 (MK2)	1
T137.003.N	Taper 3 (MK3)	1
T137.030.N	ISO 30/BT 30	1
T137.040.N	ISO 40/BT 40	1
T137.125.N	HSK25 A - C - E	2
T137.132.N	HSK32 A - C - E	2
T137.140.N	HSK40 A - C - E	2
T137.150.N	HSK50 A - C - E	2
T137.250.N	HSK50 B - D - F	2
T137.163.N	HSK63 A - C - E	2
T137.263.N	HSK63 B - D - F	2

COLLET WIPERS

ART. T137

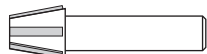

- To maintain the inside of the collet taper part clean
- To avoid wrong positioning of the collet due to resin
- For all collet types

Item	Collet type
T137.516.N	ER16
T137.520.N	ER20
T137.525.N	ER 25-ETS 25-DIN6499
T137.532.N	ER 32-ETS 32-DIN6499
T137.540.N	ER 40-ETS 40-DIN6499
T137.662.N	EOC 25-DIN 6388

BRUSHES FOR COLLET BORE

ART. T137



- To clean the collet bore
- To avoid wrong tool positioning caused by resin

Item	Collet bore
T137.906.N	3÷6
T137.911.N	6,4÷11
T137.918.N	12÷18
T137.925.N	19÷25

X137.004.N Collet brush set 3÷25



WIPE OFF KIT FOR CNC

ART. X137



- For a perfect maintenance of your CNC router or machining centres
- For cleaning boring machines and CNC router machines. Ensures **extreme cleanliness of tapered spindles and it maintains the precision and prolongs the life of your expensive machines, cutting tools and toolholders**
- Carton box
- Available for every tool holders cone and spring collets
- A complete set with:
 - Spindle wipers for every kind of tool holder (Item T137);
 - Collet wiper to avoid wrong positioning of the collet (Item T137);
 - No° 4 brushes for collet bore (Item X137)

Item	Description
X137.000.N	HSK63F/ER32 T137.263.N + T137.532.N + X137.004.N
X137.001.N	ISO30/ER32 T137.030.N + T137.532.N + X137.004.N
X137.002.N	HSK63F/DIN6388 T137.263.N + T137.662.N + X137.004.N
X137.003.N	HSK25E/ER 16 T137.125.N + T137.516.N + X137.004.N
X137.005.N	HSK63F/ER40 T137.263.N + T137.540.N + X137.004.N
X137.006.N	ISO30/ER40 T137.030.N + T137.540.N + X137.004.N
X137.010.N	HSK32E/ER25 T137.132.N + T137.525.N + X137.004.N
X137.011.N	HSK40E/ER25 T137.140.N + T137.525.N + X137.004.N
X137.012.N	HSK50E/ER32 T137.150.N + T137.532.N + X137.004.N
X137.013.N	HSK50F/ER32 T137.250.N + T137.532.N + X137.004.N

ADJUSTABLE DEMOUNT DEVICES

ART. T139

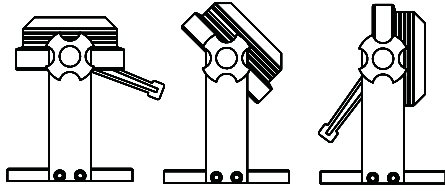

- The tool holder has to be blocked on the flange diameter which is made in special and durable steel
- **Auto-locking roller bearing design for the fastest tool changes and no slippage**
- It is adjustable from 0° to 90°
- Wide range of tightening stand/locking devices available for HSK32, HSK40, HSK50, HSK63, ISO30 and ISO40 spindles
- **Easy to be mount near the machine thanks to four holes on the basement. NB: Tightening device must be fixed before using**

Item	Collet chuck
T139.132.N	For HSK32 tool holder Ø 32 mm
T139.140.N	For HSK40 tool holder Ø 40 mm
T139.150.N	For ISO 30/HSK50 tool holder with Ø 50 mm flange
T139.157.N	For ISO 30 tool holder with Ø 57 mm flange (Thermwood machines)
T139.158.N	For ISO 30 tool holder Ø 58 (Motor ELTE/ESSETEAM)
T139.163.N	For HSK63 tool holder Ø 63
T139.164.N	For ISO 40 tool holder Ø 63,5

DEMOUNT DEVICES FOR FLANGE Ø80 - Ø85

ART. T139

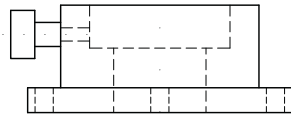

- Tool holder to be blocked on the flange diameter
- **Easy to be mount near the machine thanks to four holes on the basement. NB: Tightening device must be fixed before using**
- **Auto-locking roller bearing design for the fastest tool changes and no slippage**

Item	Collet chuck
T139.180.N	For tool holder Ø 80 mm
T139.185.N	For tool holder Ø 85 mm (Weinig, SCM)

DEMOUNT DEVICES

ART. T139

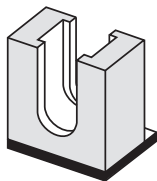

Suitable for toolholders with key seat 41 mm

Item	
T139.003.N selling out	For ISO 40 tool holder Ø 63,5

SOLID CARBIDE ROUTER BITS

Klein offers a very wide range of solid carbide router bits which can satisfy almost all the request of the market of CNC router machine.

HW SOLID CARBIDE SPIRAL CUTTER FOR PORTABLE AND CNC ROUTERS

Standard HW straight bits	<p>Straight Cut</p>	<p>Up cut spirals for an excellent finish on the bottom side of the panel pushing wood chips upward.</p>	<p>UP CUT style</p>
<p>Down cut spirals for an excellent finish on the top side of the panel pushing wood chips downward</p>	<p>DOWN CUT style</p>	<p>Compression spirals for an excellent finish on both sides of the panels, especially on laminates and double-sided melamine (UP & DOWN).</p>	<p>COMPRESSION spiral</p>

NUMBER OF TEETH:

- Z=1:** allow heavy duties on soft materials and an excellent chip evacuation
- Z=2:** allow a better finish on hard materials and a good chip evacuation
- Z=3:** allow an excellent finish on all types of materials
- Z=2/Z=3 with chipbreaker:** ideal for heavy duties
- Z=3:** with semi finishing chip-braker execution

N.B.: Increasing the number of teeth should increase also the feed speed in order to preserve the tool from burning or early wearing out.

Minimum clamping tool length	
Shank diameter S (mm)	Minimum length K (mm)
S ≤ 10	K ≥ 20
10 < S < 25	K = S x 2
S ≥ 25	K = S x 1,8

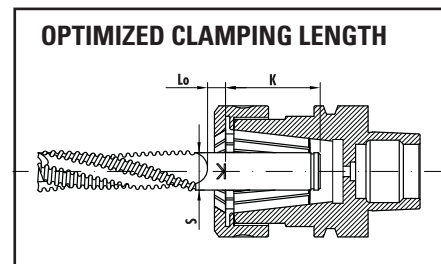
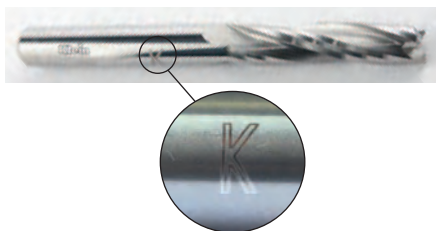

N.B.: All **Klein** spiral router bits have technical data, dimensions and type of material marked on the shank. Moreover the sign **K** indicates the minimum clamping length according to the standard EN847-2

The following reference tables are provided just as a guide, while various other conditions must be always taken in consideration, such as the characteristics of the wood piece (humidity, veins, etc.), the machine and tooling conditions, etc.

HOW TO CHOSE THE RIGHT SOLID CARBIDE SPIRAL BIT FOR ROUTING ON A CNC MACHINE

Router Bits Klein	Softwood (Cider, Poplar, Pine, etc.)	Hardwood (Ash, Walnut, Beech, Oak, Teak, etc.)	Pressed Wood (Plywood, Blockboard)	Laminated Wood (Veneered, melamine coated panels, HPL, etc.)
T141/T151 - Z=1 - Page 7.53/7.57	XXX	XXX	X	-
T142/T152 - Z=2 - Page 7.54/7.57	XXX	XXX	X	XX
T143/T153 - Z=3 - Page 7.55/7.58	XX	XX	XXX	XXX
T144/T154 - Z=3 With chipbreaker Page 7.56/7.58	XXX	XXX	XXX	XX
T155 - Z=1+1 - Page 7.59	XX	XX	X	X
T156 - Z=2+2 - Page 7.59	X	XX	XXX	XXX
T170/T171 - Z=2 With chipbreaker Page 7.64/7.65	X	X	XX	XX

X = Satisfactory
 XX = Good
 XXX = Excellent
 - = not suggested



Technical data and images are just an indication. **SISTEMI** srl reserves the right to modify the above information at any time and without notice

REFERENCE TABLE FOR CALCULATING FEEDING RATES IN THE WOODWORKING

 Reference table for calculating feeding rates (mt/min⁻¹) at RPM 18.000

DIAMETER	ITEM	SOFTWOOD	HARDWOOD	MDF	LAMINATED WOOD
Ø 3	T141	2,40	2,40	2,40	-
	T142	3,20	2,60	3,00	-
	T143	-	-	-	-
	T144	-	-	-	-
	T156	-	-	-	-
Ø 6	T141	3,70	3,60	3,40	-
	T142	4,00	3,70	3,90	-
	T143	-	-	-	-
	T144	-	-	-	-
	T156	-	-	-	-
Ø 8	T141	4,30	4,00	3,80	-
	T142	5,00	4,30	4,90	-
	T143	6,00	4,60	5,20	5,80
	T144	8,20	6,60	6,80	-
	T156	6,60	5,20	5,70	6,50
Ø 10	T141	4,90	4,90	3,80	-
	T142	6,20	4,60	5,40	-
	T143	7,30	5,00	6,10	6,80
	T144	9,10	6,60	7,40	-
	T156	6,70	5,10	6,00	6,60
Ø 12	T141	5,10	4,90	4,20	-
	T142	6,50	5,20	5,40	-
	T143	7,90	6,30	6,80	7,40
	T144	10,20	8,10	8,30	-
	T156	6,90	5,10	6,00	6,70
Ø 16	T141	-	-	-	-
	T142	7,70	6,10	6,90	-
	T143	9,50	7,90	8,10	9,10
	T144	11,80	9,00	9,50	-
	T156	7,30	6,00	6,30	6,80
Ø 20	T141	-	-	-	-
	T142	8,60	7,30	7,90	-
	T143	10,80	8,50	8,90	10,00
	T144	15,00	11,00	11,90	-
	T156	8,00	6,90	7,20	7,00

Technical data and images are just an indication. SISTEMI srl reserves the right to modify the above information at any time and without notice.

THE RECOMMENDED FEED RATES WERE CALCULATED TAKING IN CONSIDERATION THE FOLLOWING PARAMETERS:

 - **efficient machinery** in excellent conditions; - **wood piece** perfectly clamped; - **working solid material** (if not, parameters can be increased) - **wood piece dry**.

for working softwood	Good	Excellent
Single pass	T155+T141/T151	T142/T152
Roughing	T144/T154	T144/T154
Finishing	T142/T152	T143/T153

for working hardwood	Good	Excellent
Single pass	T142/T152	T142/T152
Roughing	T144/T154	T144/T154
Finishing	T142/T152	T143/T153

for working MDF	Good	Excellent
Single pass	T142	T145
Roughing	T170	T144
Finishing	T145	T143

for working laminated and veneered chipboard	Good	Excellent
Single pass	T156	T156

for working hard plastic (nylon, corian®, acrylic)	Good	Excellent
Single pass	T141	T142
Roughing	T170	T144
Finishing	T156/T142	T156/T142

Conversion chart inch/mm

Inches - Millimeters	Inches - Millimeters	Inches - Millimeters
1/32" = 0,794	1/4" = 6,35	5/8" = 15,875
1/16" = 1,588	5/16" = 7,938	3/4" = 19,050
1/8" = 3,175	3/8" = 9,525	7/8" = 22,225
3/16" = 4,762	1/2" = 12,7	1" = 25,4

KleinDIA®

DLC COATING FOR EXCELLENT PERFORMANCE AND LONGER LIFETIME

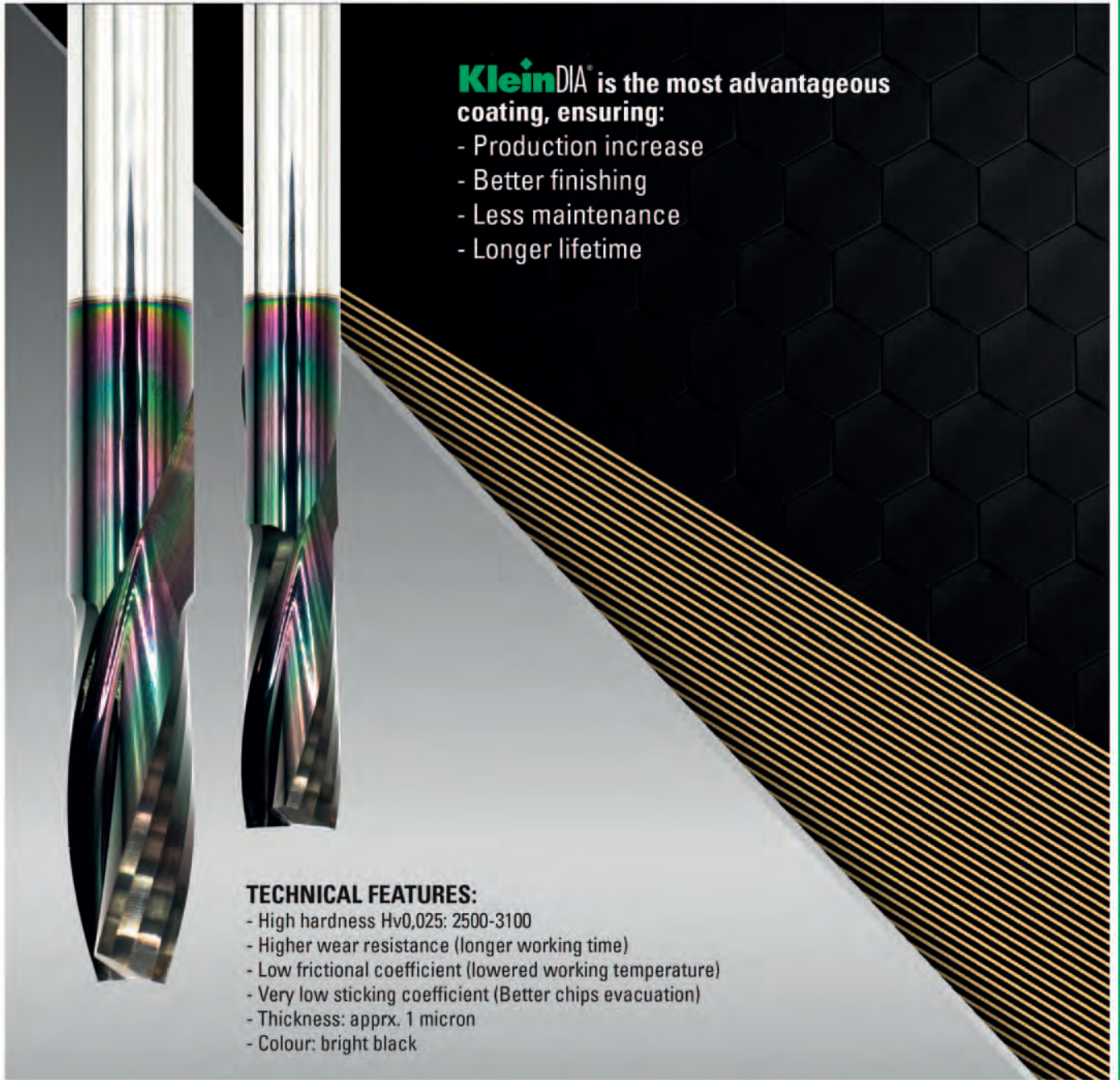

KleinDIA® is the most advantageous coating, ensuring:

- Production increase
- Better finishing
- Less maintenance
- Longer lifetime

TECHNICAL FEATURES:

- High hardness Hv0,025: 2500-3100
- Higher wear resistance (longer working time)
- Low frictional coefficient (lowered working temperature)
- Very low sticking coefficient (Better chips evacuation)
- Thickness: approx. 1 micron
- Colour: bright black



SOFTWOOD - HARDWOOD



MDF - CHIPBOARD



VENEERED AND LAMINATES



ADVANCED MATERIALS



ALUMINIUM



PLASTIC MATERIAL
SOLID SURFACE



PLASTIC COATED



PLEXIGLASS

UP TO
4/6X
TOOL LIFE

HW ROUTER BITS Z=2

ART. T110

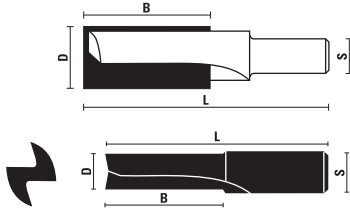

RH rotation	D	B	L	S
T110.030.R ▲	3	8	38	9,5x20
T110.040.R ▲	4	10	39	9,5x20
T110.050.R ▲	5	12	41	9,5x20
T110.060.R ▲	6	16	43	9,5x20
T110.070.R ▲	7	18	45	9,5x20
T110.080.R ▲	8	20	48	9,5x20
T110.081.R ▲	8	30	60	9,5x20
T110.090.R ▲	9	22	52	9,5x20
T110.100.R ▲	10	24	52	9,5x20
T110.101.R ▲	10	35	65	9,5x20
T110.120.R ▲	12	30	60	12x20
T110.121.R ▲	12	40	70	12x20
T110.130.R selling out	13	30	60	12x20
T110.140.R	14	40	65	12x20
T110.160.R	16	40	65	12x20
T110.180.R	18	40	70	12x20
T110.200.R	20	40	70	12x20
T110.220.R	22	40	70	12x20
T110.240.R	24	40	70	12x20
T110.250.R	25	40	70	12x20
T110.260.R selling out	26	42	70	12x20
T110.280.R selling out	28	42	70	12x20
T110.300.R selling out	30	42	70	12x20

▲ Solid carbide

VHW ROUTER BITS Z=2

ART. T112



- Solid carbide
- Indicated for plastic and acrylic material, plexiglass, polypropylene etc.
- "O" flute straight

RH rotation	D	B	L	S
T112.050.R	5	12	48	5
T112.060.R	6	14	50	6
T112.080.R	8	18	55	8
T112.100.R	10	20	58	10
T112.120.R	12	26	64	12

SOLID CARBIDE SPIRAL CUTTERS, FINISH STYLE Z=1

ART. T141

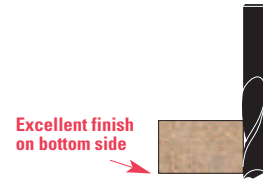
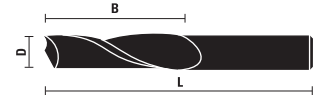

Excellent finish on bottom side

- Right-hand rotation with "UP CUT SPIRAL"

- To be used on machining centres, CNC routers and point to point machines

RH rotation	D	B	L	Z
T141.030.R	3	12	50	1
T141.040.R	4	12	50	1
T141.050.R	5	17	50	1
T141.060.R	6	17	60	1
T141.061.R	6	27	60	1
T141.064.R	6,4	28	60	1
T141.080.R	8	22	80	1
T141.081.R	8	32	80	1
T141.100.R	10	32	80	1
T141.101.R	10	42	100	1
T141.120.R	12	32	80	1
T141.121.R	12	42	100	1

Router bits with diameter from 12 mm, are produced with shank for Seeger retaining rings



SOLID CARBIDE SPIRAL CUTTERS, FINISH STYLE Z=1

ART. T141

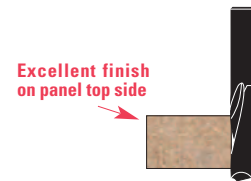
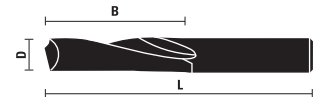

Excellent finish on panel top side

- Left-hand rotation with "DOWN CUT SPIRAL"

- To be used on machining centres, CNC routers and point to point machines

LH rotation	D	B	L	Z
T141.061.L	6	27	60	1
T141.080.L	8	22	80	1
T141.081.L	8	32	80	1
T141.100.L	10	32	100	1

SOLID CARBIDE SPIRAL CUTTERS, FINISH STYLE Z=2

ART. T142

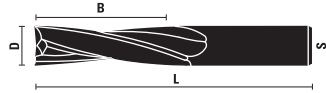

Excellent finish on bottom side



- Right-hand rotation with "UP CUT SPIRAL"
- To be used on machining centres, CNC routers and point to point machines

RH rotation	D	B	L	Z
T142.030.R	3	12	50	2
T142.032.R	1/8"	1/2"	2"	2
T142.040.R	4	12	50	2
T142.048.R	3/16"	3/4"	2"	2
T142.050.R	5	17	50	2
T142.060.R	6	17	60	2
T142.061.R	6	27	60	2
T142.064.R	1/4"	3/4"	2"	2
T142.065.R	1/4"	1-1/4"	2-1/2"	2
T142.079.R	5/16"	1"	2-1/2"	2
T142.080.R	8	22	80	2
T142.081.R	8	35	80	2
T142.095.R	3/8"	1-1/4"	3"	2
T142.100.R	10	35	80	2
T142.101.R	10	45	100	2
T142.110.R	11	35	80	2
T142.111.R	11	45	100	2
T142.120.R	12	35	80	2
T142.121.R	12	45	100	2
T142.122.R	12	55	100	2
T142.127.R	1/2"	1-1/4"	3"	2
T142.128.R	1/2"	2"	4"	2
T142.140.R	14	45	100	2
T142.141.R	14	55	100	2
T142.142.R	14	80	140	2
T142.160.R	16	45	100	2
T142.161.R	16	55	100	2
T142.162.R	16	72	120	2
T142.180.R	18	55	100	2
T142.181.R	18	72	120	2
T142.182.R	18	102	150	2
T142.200.R	20	55	100	2
T142.201.R	20	72	120	2
T142.202.R	20	102	150	2

HOW TO DETERMINE THE FEEDING SPEED RELATING TO THE DIAMETER:

- Referring to item T142 with right hand rotation (UP CUT STYLE), Z=2
- RPM 18.000

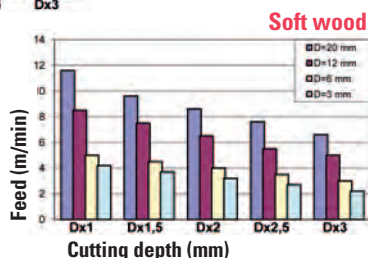
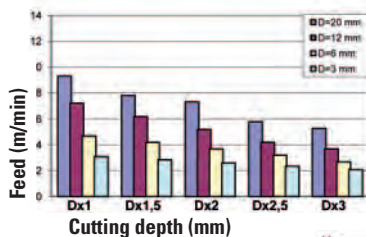

SOLID CARBIDE SPIRAL CUTTERS FINISH STYLE Z=2, KleinDIA COATED

ART. T142.KD

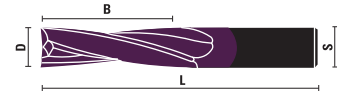

UP TO 4/6X TOOL LIFE

Excellent finish on bottom side



- Right-hand rotation with "UP CUT SPIRAL"
- Polished and coated cutting edge for improved chip evacuation and less friction for excellent performance
- Longer tool life and greater cutting quality
- For softwood and hardwood, chipboard, MDF, HF, plywood, plastic coated, mineral materials (CORIAN® ecc.)

RH rotation	D	B	L	Z
T142.030.RKD	3	12	50	2
T142.040.RKD	4	12	50	2
T142.050.RKD	5	17	50	2
T142.060.RKD	6	17	60	2
T142.061.RKD	6	27	60	2
T142.080.RKD	8	22	80	2
T142.081.RKD	8	35	80	2
T142.100.RKD	10	35	80	2
T142.101.RKD	10	45	100	2
T142.121.RKD	12	45	100	2

SOLID CARBIDE SPIRAL CUTTERS, FINISH STYLE Z=2

ART. T142

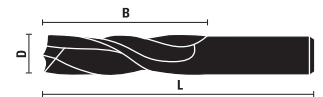

Excellent finish on panel top side



- Left-hand rotation with "DOWN CUT SPIRAL"
- To be used on machining centres, CNC routers and point to point machines

LH rotation	D	B	L	Z
T142.030.L	3	12	50	2
T142.040.L	4	12	50	2
T142.060.L	6	17	60	2
T142.081.L	8	35	80	2
T142.100.L	10	35	80	2
T142.120.L	12	35	90	2
T142.140.L	14	45	100	2
T142.160.L	16	45	100	2
T142.161.L	16	55	100	2
T142.180.L	18	55	115	2
T142.182.L	18	102	165	2
T142.200.L	20	55	120	2

Router bits with diameter from 12 mm to 20 mm, are produced with shank for Seeger retaining rings



SOLID CARBIDE SPIRAL CUTTERS, FINISH STYLE Z=3

ART. T143

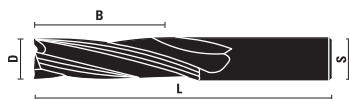

Excellent finish on bottom side



- Right-hand rotation with "UP CUT SPIRAL"

- To be used on machining centres, CNC routers and point to point machines

RH rotation	D	B	L	Z
T143.080.R	8	22	80	3
T143.081.R	8	35	80	3
T143.100.R	10	35	80	3
T143.101.R	10	45	100	3
T143.120.R	12	35	80	3
T143.121.R	12	45	100	3
T143.122.R	12	55	100	3
T143.140.R	14	45	100	3
T143.141.R	14	55	100	3
T143.160.R	16	45	100	3
T143.161.R	16	55	100	3
T143.162.R	16	72	120	3
T143.180.R	18	55	100	3
T143.181.R	18	72	120	3
T143.182.R	18	102	150	3
T143.200.R	20	55	100	3
T143.201.R	20	72	120	3
T143.202.R	20	102	150	3
T143.250.R	25	102	150	3

Router bits with diameter from 12 mm to 25 mm, are produced with shank for Seeger retaining rings



HOW TO DETERMINE THE FEEDING SPEED RELATING TO THE DIAMETER:

- Referring to item T143 with right hand rotation (UP CUT STYLE), Z=3
- RPM 18.000

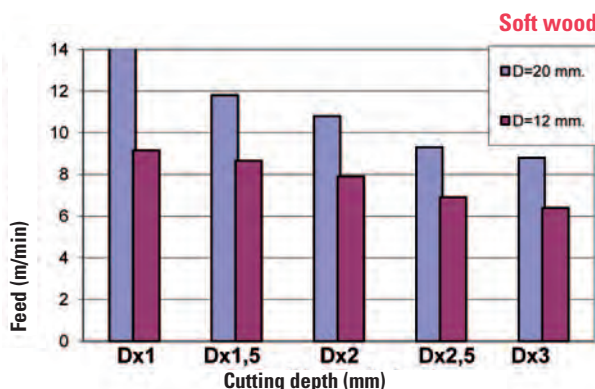
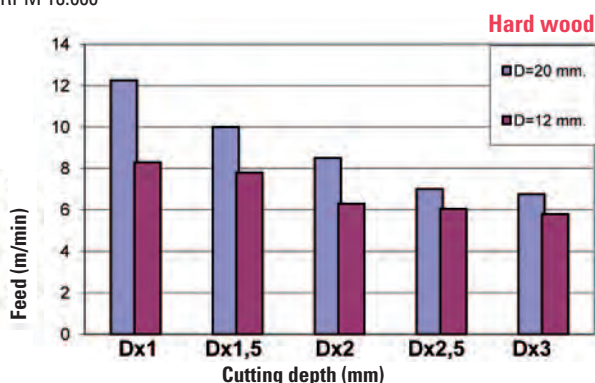

SOLID CARBIDE SPIRAL CUTTERS FINISH STYLE Z=3, KleinDIA COATED

ART. T143.KD

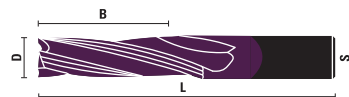

UP TO
4/6X
TOOL LIFE

Excellent finish on bottom side



- Right-hand rotation with "UP CUT SPIRAL"

- Polished and coated cutting edge for improved chip evacuation and less friction for excellent performance

- Longer tool life and greater cutting quality

- For softwood and hardwood, chipboard, MDF, HF, plywood, plastic coated, mineral materials (CORIAN® ecc.)

RH rotation	D	B	L	Z
T143.081.RKD	8	35	80	3
T143.100.RKD	10	35	80	3
T143.101.RKD	10	45	100	3
T143.121.RKD	12	45	100	3

SOLID CARBIDE SPIRAL CUTTERS, FINISH STYLE Z=3

ART. T143

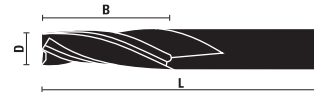

Excellent finish on panel top side



- Left-hand rotation with "DOWN CUT SPIRAL"

- To be used on machining centres, CNC routers and point to point machines

LH rotation	D	B	L	Z
T143.081.L	8	35	80	3
T143.101.L	10	45	100	3
T143.120.L	12	35	85	3
T143.160.L	16	45	100	3
T143.180.L	18	55	115	3
T143.200.L	20	55	115	3
T143.201.L	20	72	130	3

Router bits with diameter from 12 mm to 20 mm, are produced with shank for Seeger retaining rings



SOLID CARBIDE SPIRAL CUTTERS, ROUGHING STYLE Z=3

ART. T144

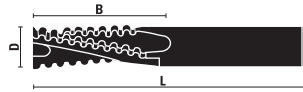

- Right-hand rotation with "UP-CUT STYLE"
- Chip-breaker execution
- To be used on machining centres, CNC routers and point to point machines
- Suitable for roughing, they guarantee a high feed rate

RH rotation	D	B	L	Z
T144.080.R	8	22	80	3
T144.081.R	8	35	80	3
T144.095.R	3/8"	1"	3"	3
T144.100.R	10	35	80	3
T144.101.R	10	45	100	3
T144.120.R	12	35	80	3
T144.121.R	12	45	100	3
T144.122.R	12	55	100	3
T144.123.R	12	42	90	3
T144.127.R	1/2"	1-1/8"	3"	3
T144.128.R	1/2"	1-5/8"	3-1/2"	3
T144.140.R	14	45	100	3
T144.141.R	14	55	100	3
T144.142.R	14	58	110	3
T144.159.R	5/8"	2"	4"	3
T144.160.R	16	45	100	3
T144.161.R	16	55	100	3
T144.162.R	16	72	120	3
T144.163.R	16	62	110	3
T144.180.R	18	55	100	3
T144.181.R	18	72	120	3
T144.182.R	18	102	150	3
T144.191.R	3/4"	2"	4"	3
T144.200.R	20	55	100	3
T144.201.R	20	72	120	3
T144.202.R	20	102	150	3
T144.250.R	25	102	155	3
T144.251.R NEW	25	130	195	3

HOW TO DETERMINE THE FEEDING SPEED RELATING TO THE DIAMETER:

- Referring to item T144 with right hand rotation (UP CUT STYLE), Z=3
- RPM 18.000

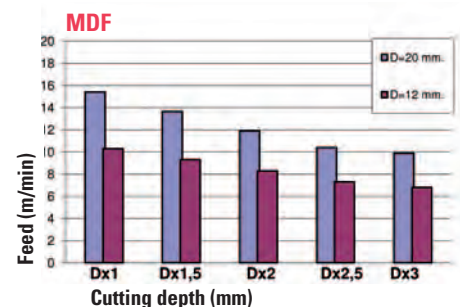
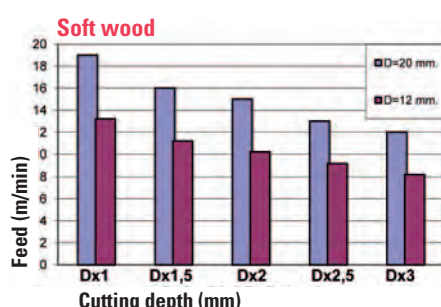
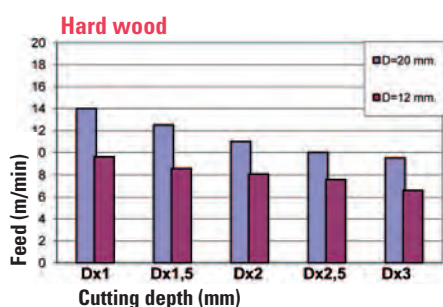

SOLID CARBIDE SPIRAL CUTTERS ROUGHING STYLE Z=3, Klein^{DIA} COATED

ART. T144.KD

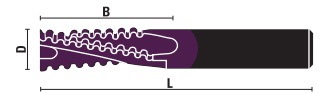

UP TO
4/6X
TOOL LIFE

- Right-hand rotation with "UP CUT SPIRAL"
- Polished and coated cutting edge for improved chip evacuation and less friction for excellent performance
- Chip-breaker execution
- Longer tool life and greater cutting quality
- Suitable for roughing, they guarantee a high feed rate

RH rotation	D	B	L	Z
T144.081.RKD	8	35	80	3
T144.100.RKD	10	35	80	3
T144.101.RKD	10	45	100	3
T144.121.RKD	12	45	100	3
T144.161.RKD	16	55	100	3

SOLID CARBIDE SPIRAL CUTTERS, ROUGHING STYLE Z=3

ART. T144

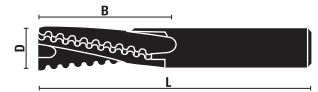

- Left-hand rotation with "DOWN-CUT STYLE"
- Chip-breaker execution
- To be used on machining centres, CNC routers and point to point machines
- Suitable for roughing, they guarantee a high feed rate

LH rotation	D	B	L	Z
T144.081.L	8	35	80	3
T144.100.L	10	35	80	3
T144.121.L	12	45	100	3
T144.122.L	12	55	105	3
T144.141.L	14	55	110	3
T144.160.L	16	45	100	3
T144.161.L	16	55	110	3
T144.162.L	16	72	125	3
T144.180.L	18	55	115	3
T144.200.L	20	55	115	3

SOLID CARBIDE SPIRAL CUTTERS Z=3

ART. T146 - T147

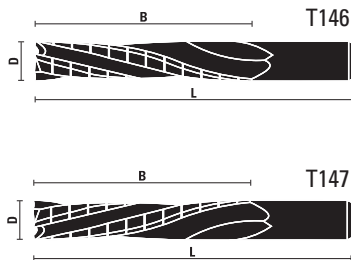

- Right-hand rotation with "UP CUT SPIRAL" (art. T146)
- Left-hand rotation with "UP CUT SPIRAL" (art. T147)
- Discontinuous cutting edge
- To be used on machining centres, CNC routers and point to point machines

RH rotation	D	B	L	Z
T146.250.R	25	140	200	3

LH rotation	D	B	L	Z
T147.250.L	25	140	200	3

SOLID CARBIDE SPIRAL CUTTERS, FINISH STYLE Z=1

ART. T151

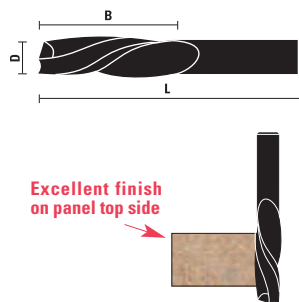

- Right-hand rotation with "DOWN CUT SPIRAL"
- To be used on machining centres, CNC routers and point to point machines

RH rotation	D	B	L	Z
T151.030.R	3	12	50	1
T151.040.R	4	12	50	1
T151.050.R	5	17	50	1
T151.060.R	6	17	70	1
T151.061.R	6	27	70	1
T151.080.R	8	22	80	1
T151.081.R	8	32	80	1
T151.100.R	10	32	80	1
T151.101.R	10	42	100	1
T151.120.R	12	32	90	1
T151.121.R	12	42	100	1
T151.122.R	12	52	110	1

SOLID CARBIDE SPIRAL CUTTERS, FINISH STYLE Z=1

ART. T151

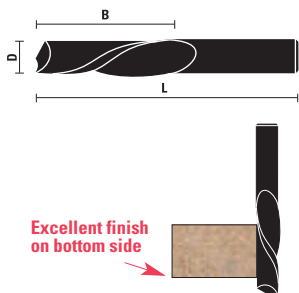

- Left-hand rotation with "UP CUT SPIRAL"
- To be used on machining centres, CNC routers and point to point machines

LH rotation	D	B	L	Z
T151.040.L	4	12	50	1
T151.061.L	6	27	60	1

SOLID CARBIDE SPIRAL CUTTERS, FINISH STYLE Z=2

ART. T152

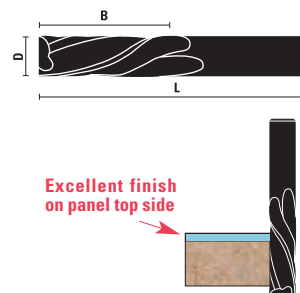

- Right-hand rotation with "DOWN CUT SPIRAL"
- To be used on machining centres, CNC routers and point to point machines

RH rotation	D	B	L	Z
T152.030.R	3	12	50	2
T152.032.R	1/8"	1/2"	2"	2
T152.040.R	4	12	50	2
T152.048.R	3/16"	3/4"	2"	2
T152.050.R	5	17	50	2
T152.060.R	6	17	70	2
T152.061.R	6	27	70	2
T152.064.R	1/4"	3/4"	2"	2
T152.065.R	1/4"	1-1/4"	2-1/2"	2
T152.079.R	5/16"	1"	2-1/2"	2
T152.080.R	8	22	80	2
T152.081.R	8	35	80	2
T152.095.R	3/8"	1-1/4"	3"	2
T152.100.R	10	35	80	2
T152.101.R	10	45	100	2
T152.110.R	11	35	80	2
T152.111.R	11	45	100	2
T152.120.R	12	35	90	2
T152.121.R	12	45	100	2
T152.122.R	12	55	110	2
T152.127.R	1/2"	1-1/4"	3"	2
T152.128.R	1/2"	2"	4"	2
T152.141.R	14	55	110	2
T152.160.R	16	45	100	2
T152.161.R	16	55	110	2
T152.180.R	18	55	115	2
T152.181.R	18	72	130	2
T152.200.R	20	55	115	2
T152.201.R	20	72	130	2

SOLID CARBIDE SPIRAL CUTTERS, FINISH STYLE Z=2

Klein^{DIA} COATED

ART. T152

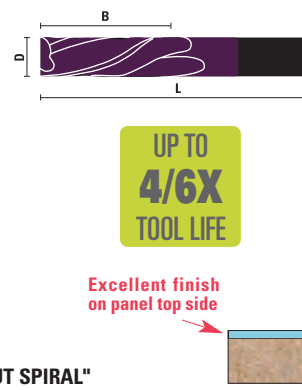

- Right-hand rotation with "DOWN CUT SPIRAL"
- Chip-breaker execution
- Longer tool life and greater cutting quality
- For softwood and hardwood, chipboard, MDF, HF, plywood, plastic coated, mineral materials (CORIAN® ecc.)

RH rotation	D	B	L	Z
T152.030.RKD	3	12	50	2
T152.040.RKD	4	12	50	2
T152.050.RKD	5	17	50	2
T152.060.RKD	6	17	70	2
T152.080.RKD	8	22	80	2
T152.101.RKD	10	45	100	2

SOLID CARBIDE SPIRAL CUTTERS, FINISH STYLE Z=2

ART. T152

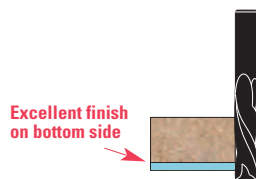
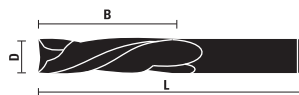

- Left-hand rotation with "UP CUT SPIRAL"

- To be used on machining centres, CNC routers and point to point machines

LH rotation	D	B	L	Z
T152.040.L	4	12	50	2
T152.060.L	6	17	60	2
T152.061.L	6	27	60	2
T152.080.L	8	22	80	2
T152.100.L	10	35	80	2
T152.120.L	12	35	80	2
T152.121.L	12	45	100	2
T152.141.L	14	55	110	2
T152.161.L	16	55	110	2
T152.181.L	18	72	120	2
T152.200.L	20	55	100	2
T152.201.L	20	72	120	2

SOLID CARBIDE SPIRAL CUTTERS, FINISH STYLE Z=3

ART. T153

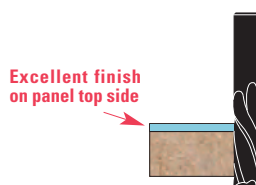

- Right-hand rotation with "DOWN CUT SPIRAL"

- To be used on machining centres, CNC routers and point to point machines

RH rotation	D	B	L	Z
T153.081.R	8	35	80	3
T153.100.R	10	35	80	3
T153.101.R	10	45	100	3
T153.120.R	12	35	85	3
T153.122.R	12	55	105	3
T153.140.R	14	45	100	3
T153.160.R	16	45	100	3
T153.161.R	16	55	110	3
T153.162.R	16	72	125	3
T153.180.R	18	55	115	3
T153.181.R	18	72	130	3
T153.200.R	20	55	115	3
T153.201.R	20	72	130	3

SOLID CARBIDE SPIRAL CUTTERS, FINISH STYLE Z=3

ART. T153

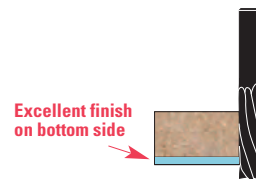
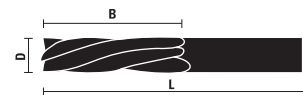

- Left-hand rotation with "UP CUT SPIRAL"

- To be used on machining centres, CNC routers and point to point machines

LH rotation	D	B	L	Z
T153.081.L	8	35	80	3
T153.100.L	10	35	80	3
T153.101.L	10	45	100	3
T153.120.L	12	35	80	3
T153.122.L	12	55	100	3
T153.140.L	14	45	100	3
T153.160.L	16	45	100	3
T153.161.L	16	55	110	3
T153.200.L	20	55	100	3
T153.201.L	20	72	120	3

SOLID CARBIDE SPIRAL CUTTERS, ROUGHING STYLE Z=3

ART. T154

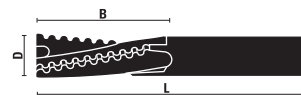

- Right-hand rotation with "DOWN CUT SPIRAL"

- Chip-breaker execution

- To be used on machining centres, CNC routers and point to point machines

- Suitable for roughing, they guarantee a high feed rate

RH rotation	D	B	L	Z
T154.080.R	8	22	80	3
T154.081.R	8	35	80	3
T154.095.R	3/8"	1"	3"	3
T154.100.R	10	35	80	3
T154.101.R	10	45	100	3
T154.120.R	12	35	83	3
T154.121.R	12	45	100	3
T154.122.R	12	55	105	3
T154.127.R	1/2"	1-1/8"	3"	3
T154.128.R	1/2"	1-5/8"	3-1/2"	3
T154.140.R	14	45	100	3
T154.159.R	5/8"	2"	4"	3
T154.160.R	16	45	110	3
T154.161.R	16	55	110	3
T154.162.R	16	72	125	3
T154.180.R	18	55	115	3
T154.181.R	18	72	130	3
T154.191.R	3/4"	2"	4"	3
T154.200.R	20	55	115	3
T154.201.R	20	72	130	3
T154.202.R	20	102	160	3

SOLID CARBIDE SPIRAL CUTTERS, ROUGHING STYLE Z=3

ART. T154



- Left-hand rotation with "UP CUT SPIRAL"
- Chip-breaker execution
- To be used on machining centres, CNC routers and point to point machines
- Suitable for roughing, they guarantee a high feed rate

LH rotation	D	B	L	Z
T154.081.L	8	35	80	3
T154.100.L	10	35	80	3
T154.120.L	12	35	80	3
T154.122.L	12	55	100	3
T154.140.L	14	45	100	3
T154.160.L	16	45	100	3
T154.161.L	16	55	110	3
T154.180.L	18	55	100	3
T154.200.L	20	55	100	3
T154.201.L	20	72	120	3
T154.250.L	25	155	220	3

SOLID CARBIDE COMPRESSION CUTTERS Z=1+1

ART. T155

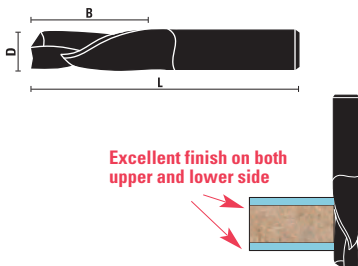

- Right-hand rotation with double flute, compression spiral
- To be used on machining centres, CNC routers and point to point machines

RH rotation	D	B	L	Z
T155.061.R	6	27	60	1+1
T155.080.R	8	22	80	1+1
T155.081.R	8	32	80	1+1
T155.100.R	10	32	80	1+1
T155.101.R	10	42	100	1+1
T155.120.R	12	42	100	1+1
T155.121.R	12	52	100	1+1
T155.127.R	12,7	32	78	1+1
T155.161.R	16	52	100	1+1

SOLID CARBIDE COMPRESSION CUTTERS Z=1+1 KleinDIA COATED

ART. T155.KD



UP TO
4/6X
TOOL LIFE

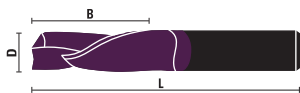

Excellent finish on both
upper and lower side

- Right-hand rotation with "DOWN CUT SPIRAL"
- Excellent finish on both upper and lower side of the panel
- Longer tool life and greater cutting quality
- To be used on machining centres, CNC routers and point to point machines
- For softwood and hardwood, chipboard, MDF, HF, double-sided melamine and laminated, plywood, plastic coated, mineral materials (CORIAN® ecc.)

RH rotation	D	B	L	Z
T155.061.RKD	6	27	60	1+1

SOLID CARBIDE COMPRESSION CUTTERS Z=1+1

ART. T155



Excellent finish on both
upper and lower side

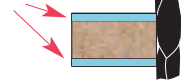

- Left-hand rotation with double flute, compression spiral
- To be used on machining centres, CNC routers and point to point machines

LH rotation	D	B	L	Z
T155.061.L	6	27	60	1+1
T155.081.L	8	32	80	1+1
T155.100.L	10	32	80	1+1
T155.120.L	12	42	100	1+1

VHW STRAIGHT ROUTER BITS FOR NESTING Z=3

ART. T113

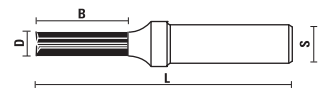

- Special extra fine quality carbide for a longer lifetime
- For nesting and grooving application
- Designed for great performance and fast feed rate up to 18 m/min
- Extra fine finishing quality

RH rotation	D	B	L	Z	S
T113.061.R NEW	6	21	73	3	12
T113.062.R NEW	6	26	73	3	12
T113.081.R NEW	8	29	76	3	12

SOLID CARBIDE COMPRESSION CUTTERS Z=2+2

ART. T156

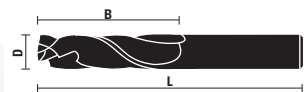

Excellent finish on both
upper and lower side

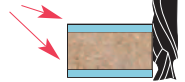

- Left-hand rotation with double flute, compression spiral
- To be used on machining centres, CNC routers and point to point machines

RH rotation	D	B	L	Z
T156.080.L	8	22	80	2+2
T156.081.L	8	32	80	2+2
T156.101.L	10	42	100	2+2
T156.120.L	12	42	100	2+2
T156.121.L	12	52	105	2+2
T156.161.L	16	52	110	2+2
T156.180.L	18	52	115	2+2
T156.200.L	20	52	115	2+2
T156.201.L	20	72	135	2+2

Router bits with diameter from 12 mm to 20 mm,
are produced with shank for Seeger retaining rings



SOLID CARBIDE COMPRESSION CUTTERS Z=2+2

ART. T156



Excellent finish on both upper and lower side

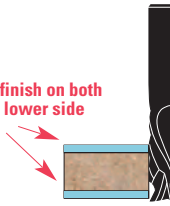

- Right-hand rotation with double flute, compression spiral
- To be used on machining centres, CNC routers and point to point machines

RH rotation	D	B	L	Z
T156.080.R	8	22	80	2+2
T156.081.R	8	32	80	2+2
T156.100.R	10	32	80	2+2
T156.101.R	10	42	100	2+2
T156.120.R	12	42	100	2+2
T156.121.R	12	52	110	2+2
T156.127.R	12,7	32	78	2+2
T156.140.R	14	42	100	2+2
T156.141.R	14	52	110	2+2
T156.160.R	16	42	100	2+2
T156.161.R	16	52	110	2+2
T156.162.R	16	72	130	2+2
T156.180.R	18	52	115	2+2
T156.181.R	18	72	135	2+2
T156.182.R	18	102	165	2+2
T156.200.R	20	52	115	2+2
T156.201.R	20	72	135	2+2

SOLID CARBIDE COMPRESSION CUTTERS Z=2+2 Klein^{DIA} COATED

ART. T156.KD



UP TO
4/6X
TOOL LIFE

Excellent finish on both upper and lower side

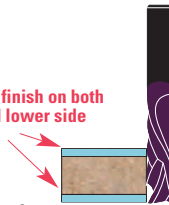

- Right-hand rotation with
- **Excellent finish on both upper and lower side of the panel**
- **Longer tool life and greater cutting quality**
- To be used on machining centres, CNC routers and point to point machines
- For **softwood and hardwood, chipboard, MDF, HF**, double-sided melamine and laminated, plywood, plastic coated, mineral materials (CORIAN® ecc.)

RH rotation	D	B	L	Z
T156.080.RKD	8	22	80	2+2

HOW TO DETERMINE THE FEEDING SPEED RELATING TO THE DIAMETER:

- Referring to item T156 with double flute, compression spiral, Z=2+2.
- RPM 18.000

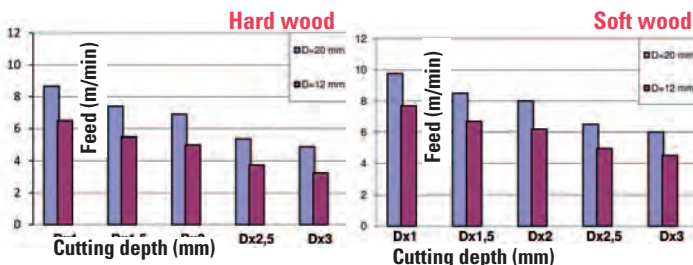

SOLID CARBIDE MORTISE COMPRESSION Z=2+2

ART. T156.M

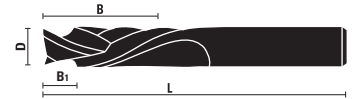

Excellent finish on both upper and lower side

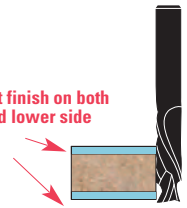

- Right-hand rotation
- **Excellent finish on both upper and lower side of the panel**
- These tools have a shorter up-cut section compared to standard compression bits. They are suitable for mortising, grooving, routing and dado
- For **softwood and hardwood, chipboard, MDF, HF**, double-sided melamine and laminated, plywood, plastic coated, mineral materials (CORIAN® ecc.)
- To be used on machining centres, CNC routers and point to point machines

RH rotation	D	B	B1	L	S
T156.095.RM	3/8"	7/8"	0,200" (5 mm)	3"	3/8"
T156.096.RM	3/8"	1-1/4"	0,200" (5 mm)	3"	3/8"
T156.125.RM	12	25	0,200" (5 mm)	80	12
T156.127.RM	1/2"	7/8"	0,200" (5 mm)	3"	1/2"
T156.128.RM	1/2"	1-1/4"	0,200" (5 mm)	3"	1/2"
T156.129.RM	1/2"	1-5/8"	0,200" (5 mm)	3-1/2"	1/2"

SOLID CARBIDE MORTISE COMPRESSION Z=2+2 Klein^{DIA} COATED

ART. T156.MKD

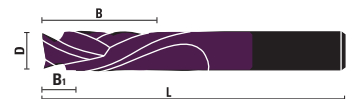

UP TO
4/6X
TOOL LIFE

Excellent finish on both upper and lower side

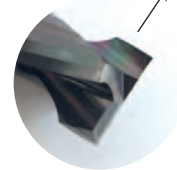

- Right-hand rotation with
- **Excellent finish on both upper and lower side of the panel**
- **Longer tool life and greater cutting quality**
- To be used on machining centres, CNC routers and point to point machines
- For **softwood and hardwood, chipboard, MDF, HF**, double-sided melamine and laminated, plywood, plastic coated, mineral materials (CORIAN® ecc.)

RH rotation	D	B	B1	L
T156.095.RMKD	3/8"	7/8"	0,200" (5 mm)	3"
T156.096.RMKD	3/8"	1-1/4"	0,200" (5 mm)	3"
T156.125.RMKD	12	25	0,200" (5 mm)	80
T156.127.RMKD	1/2"	7/8"	0,200" (5 mm)	3"
T156.128.RMKD	1/2"	1-1/4"	0,200" (5 mm)	3"

SOLID CARBIDE COMPRESSION CUTTERS Z=3+3

ART. T356

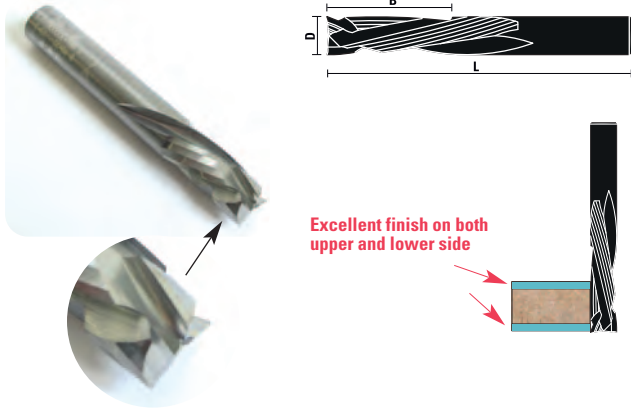

- Right-hand rotation
- To be used on machining centres, CNC routers and point to point machines
- **Excellent finish on both upper and lower side of the panel**
- For **softwood and hardwood, chipboard, MDF, HF**, plywood, plastic coated, mineral materials (CORIAN® ecc.)

RH rotation	D	B	L	Z
T356.080.R	8	22	70	3+3
T356.100.R	10	22	70	3+3
T356.101.R	10	32	70	3+3
T356.120.R	12	32	80	3+3
T356.121.R	12	42	100	3+3
T356.160.R	16	42	100	3+3
T356.161.R	16	52	100	3+3

SOLID CARBIDE COMPRESSION CUTTERS Z=3+3 KleinDIA COATED

ART. T356.KD

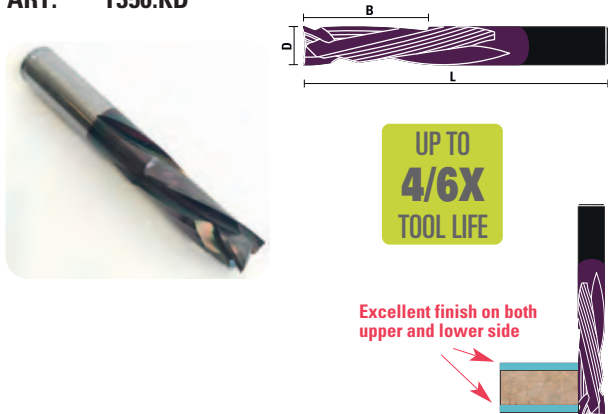

- Right-hand rotation with
- **Excellent finish on both upper and lower side of the panel**
- **Longer tool life and greater cutting quality**
- To be used on machining centres, CNC routers and point to point machines
- For **softwood and hardwood, chipboard, MDF, HF**, double-sided melamine and laminated, plywood, plastic coated, mineral materials (CORIAN® ecc.)

RH rotation	D	B	L	Z
T356.120.RKD	12	32	80	3+3
T356.121.RKD	12	42	100	3+3

SOLID CARBIDE MORTISE COMPRESSION Z=3+3

ART. T356.M

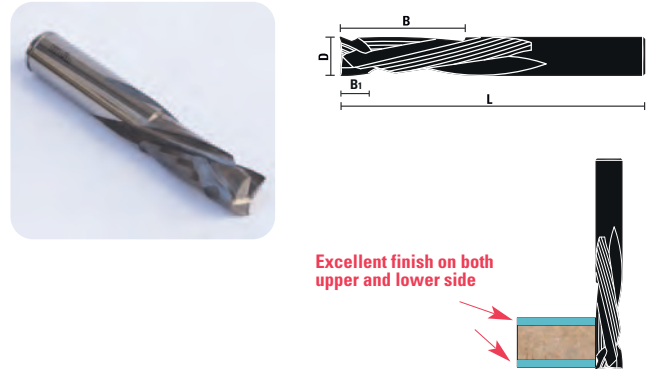

- Right-hand rotation
- **Excellent finish on both upper and lower side of the panel**
- These tools have a shorter up-cut section compared to standard compression bits. They are suitable for mortising, grooving, routing and dado
- For **softwood and hardwood, chipboard, MDF, HF**, double-sided melamine and laminated, plywood, plastic coated, mineral materials (CORIAN® ecc.)
- To be used on machining centres, CNC routers and point to point machines

RH rotation	D	B	B1	L	Z
T356.095.RM	3/8"	7/8"	0,200" (5 mm)	3"	3/8"
T356.096.RM	3/8"	1-1/4"	0,200" (5 mm)	3"	3/8"
T356.127.RM	1/2"	7/8"	0,200" (5 mm)	3"	1/2"
T356.128.RM	1/2"	1-1/4"	0,200" (5 mm)	3"	1/2"

SOLID CARBIDE MORTISE COMPRESSION Z=3+3 KleinDIA COATED

ART. T356.MKD



- Right-hand rotation with
- **Excellent finish on both upper and lower side of the panel**
- **Longer tool life and greater cutting quality**
- These tools have a shorter up-cut section compared to standard compression bits. They are suitable for mortising, grooving, routing and dado
- To be used on machining centres, CNC routers and point to point machines
- For **softwood and hardwood, chipboard, MDF, HF**, double-sided melamine and laminated, plywood, plastic coated, mineral materials (CORIAN® ecc.)

RH rotation	D	B	B1	L
T356.095.RMKD	3/8"	7/8"	0,200" (5 mm)	3"
T356.096.RMKD	3/8"	1-1/4"	0,200" (5 mm)	3"
T356.127.RMKD	1/2"	7/8"	0,200" (5 mm)	3"
T356.128.RMKD	1/2"	1-1/4"	0,200" (5 mm)	3"

SOLID CARBIDE SPIRAL CUTTERS FOR LOCK-CASE Z=2 - Z=3

ART. T157

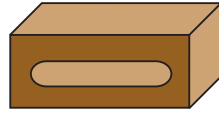
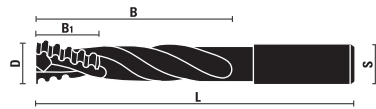

- Right-hand rotation with "UP CUT SPIRAL"
- Chip-breaker execution
- For locks and slot mortising

RH rotation	D	B1	B	L	S	Z
T157.140.R	14	20	95	155	14x45	2
T157.141.R	14	45	95	150	14x45	3
T157.160.R	16	25	115	175	16x45	2
T157.161.R	16	45	95	140	16x45	2
T157.162.R	16	50	100	150	16x45	3
T157.180.R	18	25	115	175	18x45	2
T157.181.R	18	50	100	150	18x45	3

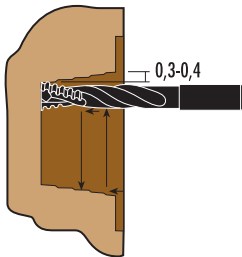

- USE EXAMPLE**
- Z=2/Z=3
 - D= 14÷18 mm: RPM 12.000-20.000
 - Stepwise processing 0,3-0,4 mm
 - Can work deeply and have excellent chip evacuation

Router bits with diameter from 14 mm to 18 mm, are produced with shank for Seeger retaining rings



SOLID CARBIDE SPIRAL CUTTERS FOR LOCK-CASE Z=3, KleinDIA COATED

ART. T357.KD

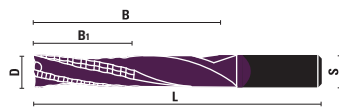

UP TO
4/6X
TOOL LIFE



- Right-hand rotation with "UP CUT SPIRAL"
- Semifinished chip-breaker execution (roughing and finishing)
- For locks and slot mortising
- Polished and coated cutting edge for improved chip evacuation and less friction for excellent performance
- To be used on machining centres, CNC routers and point to point machines
- For softwood and hardwood, chipboard, MDF, HF, plywood, plastic coated, mineral materials (CORIAN® ecc.)

RH rotation	D	B1	B	L	S	Z
T357.162.RKD	16	45	100	150	16x45	3

SOLID CARBIDE SPIRAL CUTTERS Z=3 FOR LOCKS

ART. T177 - T178

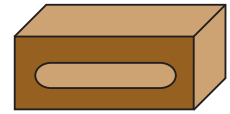
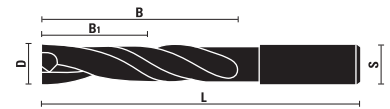

- Without chip-breaker
- For locks and slot mortising
- T177.160.R right rotation and right hand twist (positive/up cut style)
- T177.160.L left rotation and left hand twist (positive/up cut style)
- T178.160.R right rotation and left hand twist (negative/down cut style)

RH rotation	LH rotation	D	B1	B	L	S	Z
T177.160.R	T177.160.L	16	50	100	150	16x45	3
T178.160.R		16	50	100	150	16x45	3

Router bits with diameter from 16 mm, are produced with shank for Seeger retaining rings



SOLID CARBIDE SPIRAL CUTTERS Z=2

ART. T158

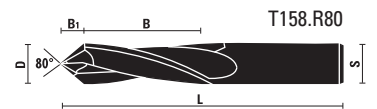
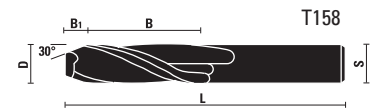

- Right-hand rotation with "UP CUT SPIRAL"
- For spy holes
- For boring and routing

RH rotation	D	B1	B	L	S	Z
T158.140.R	14	8	42	100	14	2
T158.160.R	16	9	52	120	16	2
T158.180.R	18	10	52	120	18	2
T158.200.R	20	11	52	120	20	2
T158.080.R80	8	4,8	38	80	8	2
T158.100.R80	10	6	46	100	10	2
T158.120.R80	12	7,2	50	110	12	2
T158.160.R80	16	9,6	52	120	16	2

Router bits with diameter from 12 mm to 20 mm, are produced with shank for Seeger retaining rings



SOLID CARBIDE SPIRAL CUTTERS Z=2

ART. T159

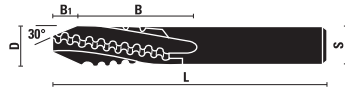

- Right-hand rotation with "UP CUT SPIRAL"
- Chip-breaker execution
- For spyholes on doors
- Through holes cutting

RH rotation	D	B1	B	L	S	Z
T159.160.R	16	9	52	120	16	2
T159.200.R	20	11	52	120	20	2

Router bits with diameter from 16 mm to 20 mm, are produced with shank for Seeger retaining rings



SOLID CARBIDE SPIRAL CUTTERS, UPCUT FINISH STYLE Z=2

ART. T160

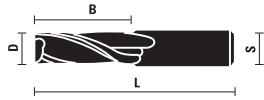

- Can also be used on portable routers
- Right-hand rotation with "UP CUT SPIRAL"

RH rotation	D	B	L	S	Z
T160.030.R	3	12	60	6	2
T160.035.R	3,5	14	60	6	2
T160.040.R	4	14	60	6	2
T160.045.R	4,5	16	60	6	2
T160.050.R	5	17	60	6	2

SOLID CARBIDE SPIRAL CUTTERS, DOWNCUT FINISH STYLE Z=2

ART. T161

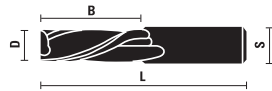

- Can also be used on portable routers
- Right-hand rotation with "DOWN CUT SPIRAL"

Rotaz. DX	D	B	L	S	Z
T161.030.R	3	12	60	6	2
T161.035.R	3,5	14	60	6	2
T161.040.R	4	14	60	6	2
T161.045.R	4,5	16	60	6	2
T161.050.R	5	17	60	6	2

SOLID CARBIDE SPIRAL CUTTERS, UPCUT FINISH STYLE Z=2

ART. T162

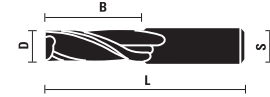

- Can also be used on portable routers
- Right-hand rotation with "UP CUT SPIRAL"

RH rotation	D	B	L	S	Z
T162.030.R	3	12	60	8	2
T162.040.R	4	14	60	8	2
T162.050.R	5	17	60	8	2
T162.060.R	6	22	70	8	2
T162.070.R	7	32	80	8	2

SOLID CARBIDE SPIRAL CUTTERS, DOWNCUT FINISH STYLE Z=2

ART. T163

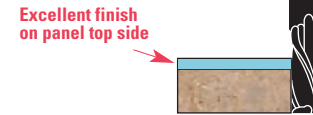

- Can also be used on portable routers
- Right-hand rotation with "DOWN CUT SPIRAL"

RH rotation	D	B	L	S	Z
T163.030.R	3	12	60	8	2
T163.040.R	4	14	60	8	2
T163.050.R	5	17	60	8	2
T163.060.R	6	22	70	8	2
T163.070.R	7	32	80	8	2

SOLID CARBIDE SPIRAL CUTTERS, FINISH STYLE Z=2

ART. T164

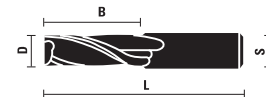

- Can also be used on portable routers
- Right-hand rotation with "UP CUT SPIRAL"

RH rotation	D	B	L	S	Z
T164.032.R	1/8"	1/2"	2"	1/4"	2
T164.048.R	3/16"	3/4"	2"	1/4"	2

SOLID CARBIDE COMPRESSION CUTTERS Z=2+2 WITH DOUBLE BALL BEARING

ART. T166

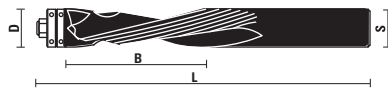

Excellent finish on both upper and lower side

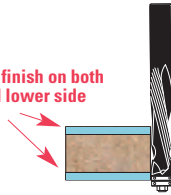

- Right-hand rotation with double flute compression spiral (UP & DOWN). The bottom part is up-cut while the upper part is down cut, ensuring excellent finish on both sides of the panel.
- Double ball bearings guide for greater precision of trimming
- Special spiral geometry which provides better chip evacuation and smoother cuts on laminate panels.

RH rotation	D	B	L	Z
T166.080.R NEW	8	36	95	2+2
T166.120.R NEW	12	51	110	2+2
T166.127.R NEW	1/2" (12,7)	1-1/4" (31,75)	4" (101,60)	2+2



Z050.032.N
(T166.080.R)



Z050.031.N
(T166.120.R)



Z050.007.N
(T166.127.R)

SOLID CARBIDE FLUSH TRIM BITS WITH DOUBLE BALL BEARINGS Z=2

ART. T168

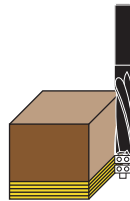
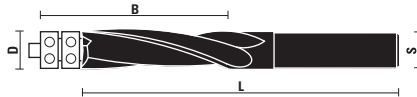

- Right-hand rotation with "UP CUT SPIRAL"
- Double ball bearings guide for **greater precision of trimming**
- Special spiral geometry which provides **better chip evacuation and smoother cuts** compared to standard flush trim bits
- For natural wood, pressed wood, veneered, laminate and melamine

RH rotation	D	B	L	S	Z
T168.064.R NEW	1/4" (6,35)	1" (25,4)	76	6	2
T168.127.R	12,7 (1/2")	51	125	12	2



Z050.017.N
(T168.064.R)



Z050.007.N
(T168.127.R)

SOLID CARBIDE SPIRAL CUTTERS "LAMELLO" KleinDIA COATED

ART. T169.KD

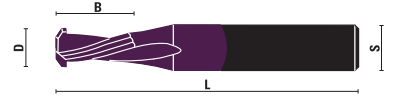
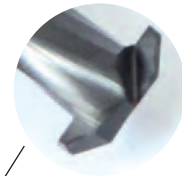

UP TO
4/6X
TOOL LIFE

- Suitable for making the groove for **Lamello P-System** with CNC router
- RH rotation
- Polished and coated cutting edge for improved chip evacuation and less friction for excellent performance
- **Longer tool life and greater cutting quality**

Item	D	B	L	S	Z
T169.098.RKD	9,8	23	80	12	2



SOLID CARBIDE SPIRAL CUTTERS, ROUGHING STYLE Z=2

ART. T170

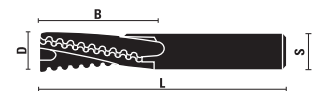

- Right-hand rotation with "UP CUT SPIRAL"
- **Chip-breaker** execution
- Z= 2 for the best chip removal

RH rotation	D	B	L	S	Z
T170.080.R	8	35	80	8	2
T170.100.R	10	35	80	10	2
T170.120.R	12	35	80	12	2
T170.121.R	12	45	90	12	2

Router bits with diameter from 12 mm, are produced with shank for Seeger retaining rings



SOLID CARBIDE SPIRAL CUTTERS, ROUGHING STYLE Z=2

ART. T171

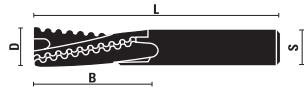

- Right-hand rotation with "DOWN CUT SPIRAL"
- Chip-breaker execution
- Z= 2 for the best chip removal

RH rotation	D	B	L	S	Z
T171.080.R	8	35	80	8	2
T171.100.R	10	35	80	10	2
T171.120.R	12	35	80	12	2

Router bits with diameter from 12 mm, are produced with shank for Seeger retaining rings



SOLID CARBIDE TAPERED BALL NOSE SPIRAL BITS Z=3

ART. T173



- Right-hand rotation with "UP CUT SPIRAL"
- Specially designed for smooth 2D and 3D carving in plastic, aluminium and wood
- Use on CNC and high speed machines

RH rotation	D	B	L	R	S
T173.008.R	1/32"	1"	3"	1/64"	1/4"
T173.009.R	0,8	25	70	0,4	6
T173.016.R	1/16"	1"	3"	1/32"	1/4"
T173.017.R	1,6	25	70	0,8	6
T173.018.R	1,6	30	80	0,8	8
T173.031.R	1/8"	1"	3"	1/16"	1/4"
T173.032.R	1/8"	2-1/2"	4"	1/16"	1/2"
T173.033.R	3,17	30	70	1,59	6
T173.034.R	3,17	50	90	1,59	8
T173.064.R	1/4"	2"	4"	1/8"	1/2"

SOLID CARBIDE SPIRAL CUTTERS RADIUS STYLE Z=2

ART. T175

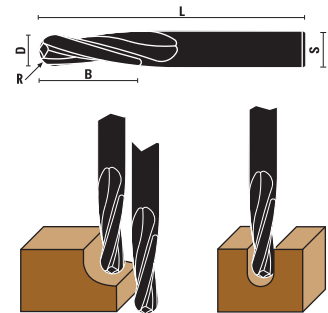

- Suitable for working plastic materials
- Right-hand rotation with "UP CUT SPIRAL"

RH rotation	D	R	B	L	S	Z
T175.030.R	3	1,5	12	50	3	2
T175.040.R	4	2	12	50	4	2
T175.060.R	6	3	22	60	6	2
T175.080.R	8	4	22	80	8	2
T175.100.R	10	5	35	80	10	2
T175.120.R	12	6	35	80	12	2
T175.160.R	16	8	55	100	16	2
T175.180.R	18	9	55	110	18	2
T175.200.R	20	10	55	110	20	2



- Perfect bit for 2D and 3D carving, deep profiling, dimensional signage, model-makers, modeling and pattern for cabinetry, sign making, furniture making
- Also known as straight ballnose router bits with straight angle and radius on top.

HS ROUTER BITS FOR "HUNDEGGER" MACHINES

ART. T244

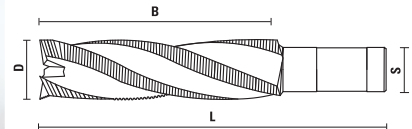

- Chip-breaker execution
- For machining lamellar beams

RH rotation	D	B	L	S	Z
T244.400.R	40	165	235	30	3
T244.500.R	50	215	295	30	3

**SOLID CARBIDE SPIRAL ROUTER BITS
FINISH/ROUGHING STYLE Klein^{DIA} COATED**

ART. T344.KD

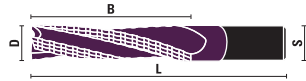

UP TO
4/6X
TOOL LIFE

Excellent finish
on bottom side



- Right-hand rotation with "UP CUT SPIRAL"
- To be used on machining centres, CNC routers and point to point machines
- Semi-finished chip-breaker execution
- For **softwood and hardwood, chipboard, MDF, HF**, plywood, plastic coated, mineral materials (CORIAN® ecc.)

RH rotation	D	B	L	Z
T344.080.RKD	8	30	80	2
T344.100.RKD	10	35	80	2
T344.120.RKD	12	35	80	3
T344.121.RKD	12	45	90	3
T344.140.RKD	14	55	110	3
T344.160.RKD	16	55	110	3
T344.161.RKD	16	75	130	3
T344.200.RKD	20	55	110	3
T344.201.RKD	20	75	130	3

**HOW TO DETERMINE THE FEEDING SPEED
RELATING TO THE DIAMETER:**

- Referring to item T344RKD with right hand rotation (UP CUT STYLE), Z=2/3
- Referring to item T354RKD with right hand rotation (DOWN CUT STYLE), Z=2/3
- Referring to item T354LKD with left hand rotation (UP CUT STYLE), Z=2/3
- RPM 18.000

Soft wood

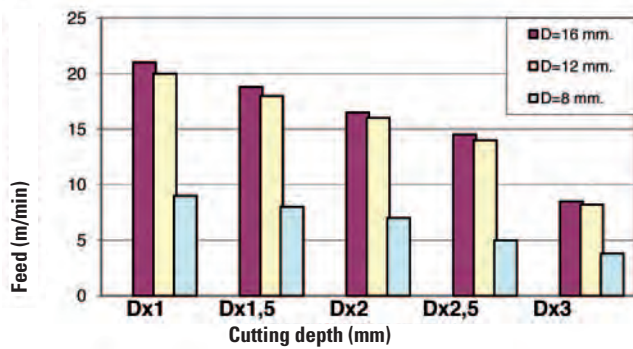

Hard wood

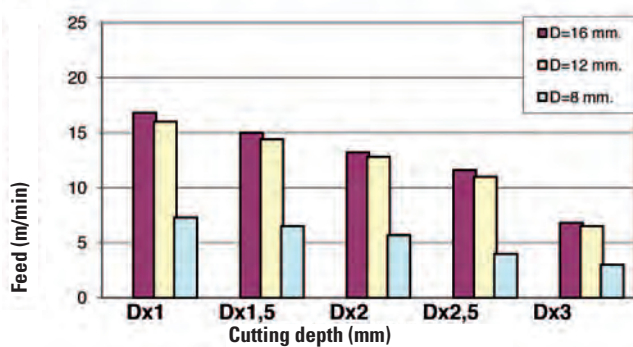

**SOLID CARBIDE SPIRAL ROUTER BITS
FINISH/ROUGHING STYLE Klein^{DIA} COATED**

ART. T354.KD

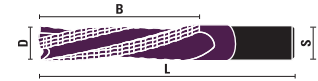

UP TO
4/6X
TOOL LIFE

Excellent finish
on panel top side



- Right-hand rotation with "DOWN CUT SPIRAL"
- To be used on machining centres, CNC routers and point to point machines
- Semi-finished chip-breaker execution
- For **softwood and hardwood, chipboard, MDF, HF**, plywood, plastic coated, mineral materials (CORIAN® ecc.)

RH rotation	D	B	L	Z
T354.100.RKD	10	35	80	2
T354.120.RKD	12	35	80	3
T354.160.RKD	16	55	110	3
T354.161.RKD	16	75	130	3
T354.200.RKD	20	55	110	3

**SOLID CARBIDE SPIRAL ROUTER BITS
FINISH/ROUGHING STYLE Klein^{DIA} COATED**

ART. T354.KD

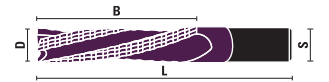

UP TO
4/6X
TOOL LIFE

Excellent finish
on bottom side



- Left-hand rotation with "UP CUT SPIRAL"
- To be used on machining centres, CNC routers and point to point machines
- Semi-finished chip-breaker execution
- For **softwood and hardwood, chipboard, MDF, HF**, plywood, plastic coated, mineral materials (CORIAN® ecc.)

LH rotation	D	B	L	Z
T354.100.LKD	10	35	80	2
T354.120.LKD	12	35	80	3
T354.160.LKD	16	55	110	3
T354.161.LKD	16	75	130	3
T354.200.LKD	20	55	110	3

Router bits with diameter from 12 mm, are produced with shank for Seeger retaining rings



TOOL KIT FOR CNC ROUTERS

ART. X118

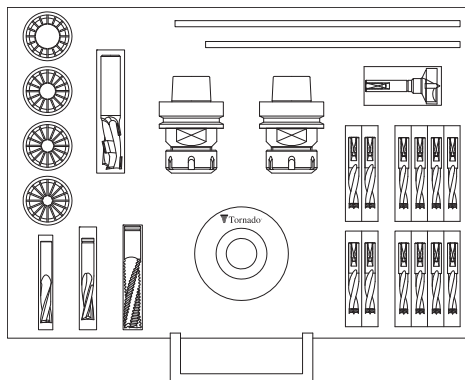

HSK63F for ER 32 spring collets

Item
X118.001.N

HSK63F for ER 40 spring collets

Item
X118.002.N

HSK63F for EOC25 spring collets

Item
X118.003.N

TOOL KIT FOR CNC ROUTERS

ART. X118

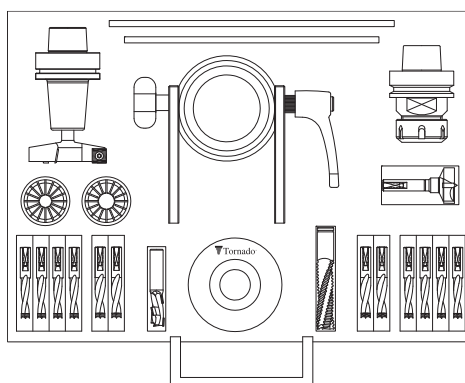

HSK63F for ER 32 spring collets

Item
X118.011.N

HSK63F for ER 40 spring collets

Item
X118.012.N

HSK63F for EOC25 spring collets

Item
X118.013.N

HW INSERT ROUTER BITS FOR ENGRAVINGS Z=1

ART. W170

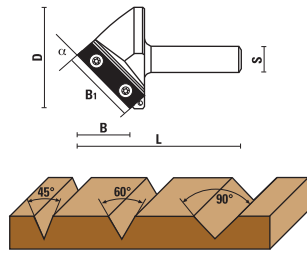

This item is sold complete with a torx key

S Ø 12	D	α	B	B1	L
W170.210.R	21	45°	25	27	61
W170.260.R	26	60°	23	27	61
W170.380.R	38	90°	19	27	76



Z051.212.R



Z052.201.N



Z055.506.N
(45°-60°)



Z055.507.N
(90°)

HW INSERT V-GROOVE ROUTER BITS Z=1

ART. W171

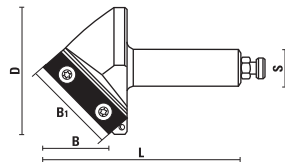

For inserting glue

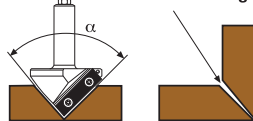

W171.670.R

W171.671.R

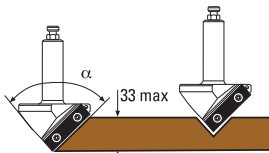

This item is sold complete with a torx key

Item	D	α	B	B1	L	S
W171.670.R	67	91°	33	46,5	97	20
W171.671.R	67	90°	33	46,5	97	20



Z051.402.R



Z052.201.N



Z055.505.N

HW INSERT SPOILBOARD CUTTER INTEGRATED WITH HSK-63F

ART. W190

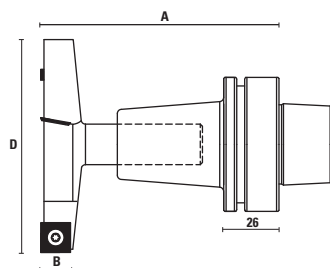

Item	Taper	D	B	A	Z
W190.100.RHSG63F	HSK-63F	100	14	116	3
W190.101.RHSG63F	HSK-63F	4"	14	112	3



Z555.007.N



Z052.205.N



Z051.205.R

HW INSERT ROUTER BITS FOR PLANING AND RABBETING

ART. W190 - WC190 - WE190 - WG190

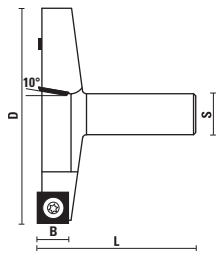

10° shear angle

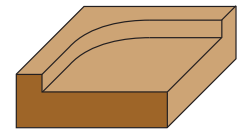

- Used for **surfacing MDF and particle board** and making deep rabbet
- **10° shear angle** for better performance
- Suitable for processing ever kind of wood
- To be used on machining centres and CNC routers
- Item WE190.380.R and WC190.350.R are suitable for working with electric portable machines
- Right-hand rotation
- For greater performance PCD knives can be mounted
- This item is sold complete with a torx key



Item	D	B	L	Z	S
W190.100.R	100	14	80	3	20x55
W190.101.R	4"	14	3"	3	3/4"x55



Z051.205.R



Z555.007.N



Z052.205.N

Item	D	B	L	Z	S
WE190.800.R	80	14	76	3	12x50



Z051.701.R



Z555.007.N



Z052.201.N

Item	D	B	L	Z	S
WE190.635.R	63,5	14	70	3	12x45
WG190.635.R	2-1/2"	14	2-3/4"	3	1/2"x45



Z051.701.R



Z555.007.N



Z052.201.N

Item	D	B	L	Z	S
WE190.380.R NEW	38	12	60	3	12



Z051.210.R



Z555.001.N



Z052.201.N

Item	D	B	L	Z	S
WC190.350.R NEW	35	10,5	60	3	8



Z051.210.R



Z055.016.N



Z052.201.N

- Suitable for **surfacing spoilboard on CNC**
- Best accuracy and precision
- Balanced at G 2,5 to 24.000 RPM
- This item is sold complete with a torx key

Spare parts: Router bit
W190.100.R

Spare parts: Collet chucks
T120.700.N For W190.100.RHSG63F

Spare parts: Router bit
W190.101.R

Spare parts: Collet chucks
T120.695.N For W190.101.RHSG63F



Klein

SISTEMI S.r.l. • 61122 PESARO - Italy - Via Montanelli, 70
Tel. +39.0721.28950 • Fax +39.0721.283476
www.sistemiklein.com • info@sistemiklein.com

